

intelligent Global Electronics Module (iGEM)



For internal use only
Endast internt bruk
Nur für den internen Gebrauch
Pour usage interne seulement
Только для внутреннего
пользования

MAINTENANCE MODE





Product Liability

For the supplier's product liability to be valid, no alterations, additions or the like may be made to the equipment without the supplier's express permission.

Use only genuine parts



Produktansvar

För att en leverantörs produktansvar skall gälla får ändringar, kompletteringar och liknande ej göras i utrustningen utan leverantörens godkännande. Originalreservdelar skall alltid användas.



Produkthaftung

Damit die Produkthaftung des Lieferanten ihre Gültigkeit behält, dürfen ohne ausdrückliche Genehmigung des Lieferanten keine Änderungen, Ergänzungen o. Ä. an der Ausrüstung vorgenommen werden. Verwenden Sie nur Originalteile.



Ответственность поставщика

Для сохранения ответственности нельзя вводить в оборудование изменения, дополнения и т.п. без разрешения поставщика. Пользуйтесь только оригинальными запасными частями, выпущенным изготовителем бензоколонки.

Caution

To prevent damage that might result in electric shock or fire, disconnect the main power prior to any work.

Varning

Gör pumpen/enheten strömlös innan Du gör ingrepp i den. I annat fall föreligger risk för skada.

Vorsicht

Um Beschädigungen zu vermeiden, die zu einem elektrischen Schlag oder Feuer führen können, unterbrechen Sie vor jeder Arbeit die Stromzufuhr.

Осторожно

Во избежание поражения электрическим током или пожара отключайте напряжение питания перед началом любых работ.

Warning

Never run a leaking pump! Be careful with the environment and mind the skidding risk; take care of leaking fuel immediately.

Varning

Använd aldrig en läckande pump. Tänk på miljön och halkrisken, sanera utläckt drivmedel snarast.

Warnung

Lassen Sie nie eine undichte Zapfsäule laufen! Seien Sie umweltbewusst und denken Sie an die Rutschgefahr; beseitigen Sie austretenden Kraftstoff umgehend.

Предупреждение

Не пользуйтесь колонкой при наличии утечки топлива! Охраняйте окружающую среду, помните об опасности скольжения: в случае утечки топлива на дорожное покрытие возле колонки, примите меры немедленно.

The contents of this publication may not be copied either wholly or in part without the consent of Dresser Wayne AB.

Dresser Wayne AB reserves the right to change specifications contained in the text and illustrations without notice.

Innehållet i denna publikation får ej helt eller delvis kopieras utan medgivande från Dresser Wayne AB.

Dresser Wayne AB förbehåller sig rätten att utan särskilt meddelande ändra specifikationer givna i text och bild.

Der Inhalt dieses Handbuchs darf ohne die Erlaubnis von Dresser Wayne weder ganz noch teilweise kopiert werden.

Dresser Wayne behält sich das Recht vor, textliche oder bildliche Inhalte ohne besondere Mitteilung zu ändern.

Не разрешается копировать полностью или частично содержание настоящей публикации без разрешения фирмы Dresser Wayne AB.

Dresser Wayne AB оставляет за собой право вносить изменения в спецификации, содержащиеся в тексте и иллюстрациях, без предварительного уведомления.

Table of Contents:

1	Introduction	6
1	Introduction	6
1.1	Technical Support	6
1.2	Revision history:.....	6
1.2.1	Release overview:.....	12
2	Maintenance Mode Overview	13
2.1	General Description	13
2.1.1	Accessing the Maintenance Mode	13
2.1.2	Performing Tasks Through the Maintenance Mode	13
2.2	Service Terminal Program STP	13
2.3	Software loading.....	13
2.4	Infrared Interface.....	13
3	Programming IGEM.....	14
3.1	Introduction	14
3.2	Infrared Interface.....	14
3.3	Service Terminal Program STP	15
3.4	Maintenance Mode Display	16
3.5	Maintenance Mode Exit.....	17
3.5.1	Exit and Save Changes.....	17
3.5.2	Quick Exit.....	17
3.6	Function or Statistic Entry Level.....	18
3.7	Sub Entry Level.....	19
3.8	Function List.....	20
3.8.1	F00 - Exit Function	20
3.8.2	F01 - Filling Modes.....	20
3.8.3	F02 - Clock Configuration	20
3.8.4	F03 - Set Side A Unit Prices	20
3.8.5	F04 - Set Side B Unit Prices.....	21
3.8.6	F05 - Set Side A Fuelling Point Address	21
3.8.7	F06- Set Side B Fuelling Point Address	21
3.8.8	F07 - Dispenser Configuration.....	21
3.8.9	F08- Side A Dispenser Type Configuration Part #1	21
3.8.10	F09 - Side B Dispenser Type Configuration Part #1	22
3.8.11	F10 - Side A Dispenser type Configuration Part #2	22
3.8.12	F11 - Side B Dispenser Type Configuration Part #2	23
3.8.13	F12 - Side A Pump Assignments	23
3.8.14	F13 - Side B Pump Assignments.....	23
3.8.15	F14 - Dispenser Display Configuration (both sides)	23
3.8.16	F15 - Dispenser Annunciator Configuration.....	24
3.8.17	F16 - WIP Configuration.....	24
3.8.18	F17 - Dispenser Limits Configuration	25
3.8.19	F18 - Blend Ratio Configuration	25
3.8.20	F19 - Volume Unit Specific Configuration.....	25
3.8.21	F20 - Dispenser Serial Link Configuration	26
3.8.22	F21 - Miscellaneous Configuration.....	27
3.8.23	F22 - Sales Amount Calculation	29
3.8.24	F23 - Miscellaneous Timers.....	29
3.8.25	F24 - Local Preset Configuration.....	30
3.8.26	F25 - Local Preset By Button Configuration	31
3.8.27	F26 - VAP Configuration.....	32
3.8.28	F27 - Side A Dispenser Configuration.....	33
3.8.29	F28 - Side B Dispenser Configuration.....	33
3.8.30	F29 - Side A Litre Flow Rate Configuration	33
3.8.31	F30 - Side B Litre Flow Rate Configuration	33
3.8.32	F31 - Side A Gallon Flow Rate Configuration	33
3.8.33	F32 - Side B Gallon Flow Rate Configuration	33
3.8.34	F33 - Password Change.....	33
3.8.35	F34 - Diagnostics.....	34
3.8.36	F35 = Side A Satellite Configuration.....	34
3.8.37	F36 = Side B Satellite Configuration	34
3.8.38	F37 - Pump Model Configuration	34

3.8.39	F38 - Country Configuration.....	35
3.8.40	F39 - Error level assignment.....	36
3.8.41	F40 - Manual VAP calibration without the Buerkert Handterminal.....	36
3.8.42	F41 - Backlight, Red/Green outputs, Spare In/Outputs assignment.....	36
3.8.43	F42 - GHM rotation.....	38
3.8.44	F43 - Motor feedback.....	38
3.8.45	F44 - Hydro Filter Configuration.....	38
3.8.46	F45 - Extended Manager Access.....	39
3.8.47	F46 - Reserved.....	39
3.8.48	F47 - Vapour Recovery Settings, Side A.....	39
3.8.49	F48 - Vapour Recovery Settings, Side B.....	39
3.8.50	F49 - Vapour Gate VR Meter Calibration Data.....	39
3.8.51	F50 - ATC, Product Type Assignment.....	40
3.8.52	F51 - ATC, Density Assignment.....	40
3.8.53	F52 - ATC, Probe # Assignment.....	40
3.8.54	F53 - ATC, Temperature Offset Adjustment.....	40
3.8.55	F54 - Miscellaneous Configuration Part 2.....	41
3.8.56	F70 - Access level.....	41
3.8.57	F96 - Upload Flash Memory Programming.....	41
3.8.58	F98 - Download Flash Memory Programming.....	41
3.8.59	F99 - Not used.....	41
3.9	Statistics List.....	42
3.9.1	S01 - Side A Totals by Logical Nozzle.....	42
3.9.2	S02 - Side B Totals by Logical Nozzle.....	42
3.9.3	S03 - Side A Error/Event Counter Totals.....	43
3.9.4	S04 - Side B Error/Event Counter Totals.....	43
3.9.5	S05 - Side A Meter Volume Totals.....	43
3.9.6	S06 - Side B Meter Volume Totals.....	43
3.9.7	S07- S10: RESERVED.....	43
3.9.8	S11 - Side A Totalizers by Logical Nozzle.....	43
3.9.9	S12 - Side B Totalizers by Logical Nozzle.....	43
3.9.10	S13 - Side A Error/Event Counter Totalizers.....	44
3.9.11	S14 - Side B Error/Event Counter Totalizers.....	44
3.9.12	S15 - Side A Meter Volume Totalizers.....	44
3.9.13	S16 - Side B Meter Volume Totalizers.....	44
3.9.14	S17 - S20: RESERVED.....	44
3.9.15	S21 - Side A Error/Event Log.....	44
3.9.16	S22 - Side B Error/Event Log.....	45
3.9.17	S23 - Side A Transaction History Log.....	45
3.9.18	S24 - Side B Transaction History Log.....	46
3.9.19	S25 - Total Number of Power Cycles.....	46
3.9.20	S26 - Reset history.....	46
3.9.21	S27 - Statistic of the WIPs.....	47
3.9.22	S28 - Side A Vapour Recovery Filling History Log.....	48
3.9.23	S29 - Side B Vapour Recovery Filling History Log.....	48
3.9.24	S30 - Reserved.....	48
3.9.25	S31 - Side A Vapour Recovery Log.....	49
3.9.26	S32 - Side B Vapour Recovery Log.....	50
3.9.27	S33 - Side A Vapour Recovery Log, Error period.....	50
3.9.28	S34 - Side B Vapour Recovery Log, Error period.....	50
3.10	Weights and Measures Mode.....	51
3.11	Readout of Totalizers/Totals in Weights and Measures Mode.....	52
4	Error Codes.....	53
4.1	Error/Event Classification.....	53
4.2	Error/Event Types.....	54
5	Miscellaneous IGEM Functions.....	58
5.1	Performing a Cold Start.....	58
5.1.1	Alternative 1: Perform a cold start to reset statistical and functional values.....	58
5.1.2	Alternative 2: Perform a Soft cold start to reset all statistical and functional values by Function Register F00.....	58
5.2	IGEM Data Dump.....	58
5.3	Pumping unit flow lost check to avoid dry operation when two meters are assigned to one nozzle.....	58
5.4	Calibration when two meters are assigned to one nozzle.....	59
5.5	Pump Motor Feedback.....	59
5.6	Nozzle out identification at power ON.....	59
5.7	40/90 Models.....	59
5.8	Vapour Gate VR Monitoring.....	60
5.8.1	Activation.....	60

5.8.2	Error Indication	60
5.8.3	Status Value in VRM log	60
5.8.4	Remote Status Indication	61
5.9	Vapour Flow Switch VR Monitoring.....	61
5.9.1	Activation	61
5.9.2	Error Indication	61
5.9.3	Status Value in VRM log	61
5.10	ATC	62
6	Software Download	63
6.1	General.....	63
6.2	Differences Between iGEM Boards	64
6.2.1	Straps & Buttons	64
6.2.2	PROGRAM MEMORY	64
6.3	Download on 1:st Generation iGEM Board.....	65
6.3.1	Bootstrapp Download PC (Notebook) to iGEM Board (pump)	65
6.3.2	Bootstrapp Download, iGEM Master (supporter Kid) to iGEM Board in pump	66
6.3.3	Function 98 Download PC (Notebook) to iGEM Board	67
	Set jumper according link type.....	67
6.3.4	Function 98 iGEM Master to iGEM Board (pump).....	68
	Set jumper according link type.....	68
6.4	Download on 2:nd Generation iGEM Board.....	69
6.4.1	Bootstrapp Download PC (Notebook) to iGEM Board (pump) with J14	69
6.4.2	Bootstrapp Download, iGEM Master (supporter Kid) to iGEM Board in pump	70
6.4.3	Function 98 Download PC Notebook to iGEM Board with J14	71
6.4.4	Function 98 iGEM Master to iGEM Board (pump).....	72
7	Notes.....	74
8	Market & Service	75



1 Introduction

This manual describes how to operate the maintenance mode of a dispenser equipped with the Global Electronics Module (iGEM).

1.1 Technical Support

Refer service problems to tech support.

Technical Support Office Locations and Phone Numbers:

See page 75 of this document.

1.2 Revision history:

Revision	Release	Description	
1.0		Creation	
1.1	7.13	Added: F00.04 soft Coldstart	
	7.13	Added: F16.02, Confirm WIP serial number change (when WIP has been replaced)	
	7.13	Added: F16.04, Verify WIP serial number change	
	7.13	Added: F20.00 new Protocol type 7 = ATCL	
	7.13	Added/changed F20.01 new Baud rate structure	
	7.13	Added: F26.01 Manual VAP Calibration without the Buerkert Handterminal	
	7.13	Added: F29.3N, F30.3N Max. full flow rate (to be used for flow selection by button -40/80 l/min.) , 10-180 (units of Liters/min.)	
	7.13	Added: F37 sub-functions	
		.01	Maximum logical nozzle number for each side
		.02	Dispenser geometry
		.03	General valve type for all primary, secondary and third valves
		.04	UPD re-orientation, left to right or right to left
		.05	UPD mapping
	7.13	Added: F39, Error level assignment	
	7.13	Added: F40, Manual VAP calibration without the Buerkert Handterminal	
	7.13	Added: F41, Backlight, Red/Green outputs, Spare In/Outputs assignment	
	7.13	Added: F42, GHM rotation (meter + valves)	
7.13	Added: S27.01-08, Statistic of the WIP (WIP serial number) S27.11-18, Number of WIP change		
1.2	7.15	Added: F10/11.6N High capacity button assignment F10/11.7N Low capacity button assignment	
	7.15	Added: F14.01 Display mode after sale paid 5 = Money and Volume is actual, Unit Price is for 5 sec. actual (U.K. request)	
	7.15	Added: F19.16 and F19.25 hose test volume	
	7.15	Changed: F19.10 = Range from 0-9.	
	7.15	Added: F21.06 = 4 Show primary volume at the amount display and secondary volume at the unit price display F21.06 = 5 flow rate indication (U.K. request) F21.06 = 6 flow rate indication (U.K. request) F21.06 = 7 flow rate indication (U.K. request) F21.06 = 8 flow rate indication (U.K. request)	

Revision	Release	Description
	7.15	Added: F23.06, hose test time
	7.15	Changed: F38, Country Configuration, 6 is now Netherlands
	7.15	Added: F41.05-08 Pulse output (e.g. Vaporix vap control system)
	7.15	Added: F41.09 Extra maintenance key (U.K. request)
	7.15	Changed: F42, GHM rotation (exchange meter only)
	7.15	Added: F43, Motor feedback indication
1.5	7.15	Added: F70, Access level configuration
	7.15	Added: S27.31-38, WIP pulse errors indication S27.41-48, WIP back pulses indication
		Added: Error 16+17, hose test volume out of tolerance
		Added: Error 36, now flow on one meter at high speed pump
1.3	7.15	Revised, F14.07/08, F20, F26.02/03, F38, F70
1.4	7.16	Added: F27/28.01, cash button assignment
		Changed: error level 54 classification changed from A to B
1.5	7.17	Added: F10/11.8N, maximum volume limit
		Added: F10/11.9N, grade code assignment
		Added: F22.04, Money rounding method
		Revised: F37.04, text for function
		Enhanced: S27, from 8 to 12 meters
		Revised: Maintenance Mode Display, chapt. 3.4, money display = current transaction side B, volume display = current transaction side A.
		Revised: chapt. 3.9 Statistics list
		Revised: error/event types, test error 36
1.6 (V1.1 of 461330)	7.19	Document revised to new template format
		Added: Introduction of pump model "PUMP MODEL 59, C11-11 S160 SAT":
		Added: Descriptions of
		- LPG-configuration (F08/09.1N = 3)
		- Enable to always enter FILLING COMPLETED on nozzle in (F20.03)
		- Preset softKey#5 in F24
		- Pump Motor Feedback
		- Calibration when two meters are assigned to one nozzle
		- Pumping unit flow lost check to avoid dry operation when two meters are assigned to one nozzle
		- Readout of Totalizers/Totals in Weights and Measures Mode
		- Bootstrapp Download PC (Notebook) to iGEM Board (pump)
		- Bootstrapp Download, iGEM Master (supporter Kid) to iGEM Board in pump
		- Function 98 Download PC (Notebook) to iGEM Board
		- Function 98 iGEM Master to iGEM Board (pump)
		Changed: Swapped sub functions F10/11.08 and F10/11.09. Grade number is now function F10/11.08 and individual nozzle limit is function F10/11.09.
1.7	7.19	Adjusted version number of document to this table +
		- added grade code description for DART (F10/11.8n)
		- added description of how to Strap HW for Ferranti/US Current Loop in F20
1.8	7.19	- added LPG Nozzle timeout description F23.07
		- corrected release overview table, date was in wrong order
1.9	7.20	Added:
		- F26.04 Vapor recovery monitoring (Fafnir Vaporix) configuration
		- Vapor recovery monitoring error/event codes 37-40

Revision	Release	Description
1.10	7.22	<ul style="list-style-type: none"> - F20.04 Use logical nozzle Totals/Totalisers Statistics as grade Totals/Totalisers Statistics <p>Added:</p> <ul style="list-style-type: none"> - OPT lamp control, OPT lamp connected to iGEM Red/Green output (J9), enabled via F41.03/04, = 5 (continuously ON); = 6 (blinking 0,5 Hz). Controlled by DART command CD7 - Minimum time between fillings (nozzle In timeout) F23.01 nozzle WILL NOT be recognised when timeout ends if set to 01-20 nozzle WILL be recognised when timeout ends if set to 21-40 <p>Changed:</p> <ul style="list-style-type: none"> - default (after coldstart) flowrate setting (F29/30.2N) from 40 to 38 l/min for pump model 50 and above. <p>Revised:</p> <ul style="list-style-type: none"> - description to F35.02
1.10	7.24	<p>Added:</p> <ul style="list-style-type: none"> - Money preset configuration, new parameter F22.03 = 03 Calculate a volume amount that will ensure a money amount is greater than or equal to the preset amount and show the actual amount at the end of the sale. - Nozzle out identification at power ON, see chapter 5.x Nozzle out identification at power ON - Download LPG calibration factor to WIP in F16.05. - Satellite configuration, F35.04 = 03 start filling on Master or SAT, simultaneous not allowed - Third pump (motor) configuration by F12/13.2N - Local authorise functionality by spare inputs, F41.09/10 = 05 - Nozzle Out indication by spare output 3 and 4, F41.07/08 = 7 - Pulses/litre configuration on spare outputs 1-4, F19.07 Changed: - F23.02, Stop for offline error, max value changed from 30 to 60
1.11	7.26	<p>Added:</p> <ul style="list-style-type: none"> - Configuration of product ID output signals (4+4) on expansion board connector J13 (pins 17 to 24 = signals, pins 15-16 = GND) by F41.11. - Physical link type configuration/strapping for new iGEM board (2. Generation of iGEM Boards). - Added download descriptions for new iGEM board design. - Added country code for Spain F38.00=9. - F21.08 can be set to display WIP totalizers in W&M mode (stop/clear button). <p>Changed:</p> <ul style="list-style-type: none"> - F16.03 default value is depending on countrycode. - Country code for Ireland (F38) = 3. - Reference to template specification #174308 replaced with reference to new document WM005057. <p>Revised:</p> <ul style="list-style-type: none"> - F20, Physical link type configuration, 4-wire DART, added - F23.01, description revised
1.12 (1.13)	7.27	<p>Added:</p> <ul style="list-style-type: none"> - new parameter chose in F41.01 and F41.02 = 2 to configure that backlight is turned off in maintenance mode. This default after coldstart. - Two-stage valves is supported and can be configured in F08 and F09.

Revision	Release	Description
		F08/09.5n = valve number of “fast flow valve” F08/09.6n = 4 → two-stage valve F08/09.7n = valve number of “slow flow valve” F08/09.8n = 4 → two-stage valve
1.14	7.28	Added: <ul style="list-style-type: none"> - new parameter choice in F20.00 = 10 for IFSF Stand Alone Mode. Also added ISFS strappings in F20 (same as RS-485). - possibility to configure hose leak test for France in F23.06 by setting parameter to 21-30 (leak test performed after filling). - new parameter for COPOS display timeout in F23.08 - Clean Air VAP signal as new option for Spare output 2 by setting F41.06 = 6 - F44 for configuration of Hydro Filter Clogging detection. Function is mapped per meter. - Error code 76 (SEMI fatal error closing pump side) in part 4.2 (Error/Event Types).
1.15	(7.29) 7.30	Added parameter to configure 40-90 Hi/Low flow functionality (or only 90) by setting product type in F08.1N and F09.1N to 4. This is only required for double sided pump (two users) models.
1.16	(7.31) 7.32	Added: <ul style="list-style-type: none"> - sub parameter 37.06 where display type can be selected (to support VISTA display as well). - Function 45, Extended Manager access. Up to 5 functions can be changed to read/write access for manager level entry. - Added statistics S28 and S29 where logical nozzle no. of the ten (10) last VR fillings are logged. - Added error codes 77 (battery low) and 78 (LPG excess flowrate).
1.17	7.33	Added: <ul style="list-style-type: none"> - Country code 10 (Italy) with restricted access according to Italian W&M demands. - CASH-button status output on Spare out 3 and 4. - General adjustments on parameters values that were incorrect.
2	(7.34) (7.35) 7.36	Added: <ul style="list-style-type: none"> - Country code 11 (Turkey) with same access to functions as Italy. No access to change mode (F01). - Nuovo Pignone serial protocol for SINP (F20.00=11) and RS485 (F20.00=12). - Tank Level Low detection on spare inputs 1 and 2 (F41.09/10=6) - Inverted nozzle switch sense to be able to use “normally open” switches (F37.07 = 1) - New configuration for EMT (F21.05 = 4) - Dry test of VR (functional test using remote control to simulate VR flow at 10/35 lpm) without having to enter maintenance mode (F26.05). - Added error code for corrupted VR data (manual calibration). - Configuration of MPI to have longer pulse width. - Clarification for 40/90 pumps without flowrate selection buttons.
2.1	7.40	- Added function F37.08 to map the EMT to position on the totalizer board (to get same left-right and right-left as UPD’s and nozzle positions)
3	9.00	- Added IFSF LON (13) and IFSF LON Stand Alone (14) as selectable protocols in F20.00. <i>NOTE! IFSF has slightly different error levels for different error types. See IFSF protocol specification for Dispenser Application for details.</i>

Revision	Release	Description
		<ul style="list-style-type: none"> - Added new option for backlight control selectable in F41.01.
3.1	9.01	<ul style="list-style-type: none"> - ServTerm2.09 or newer required in order to download V9.00. - Corrected max value of F24.03 (preset entry timeout) from 60 to 180 seconds
3.2	9.03	<ul style="list-style-type: none"> - F07.02: Added description of function for oilmix pump. - F08/09.1N: Added two new product assignment types, 5 = Oilmix, 6 = AdBlue - F20.05: New parameter, alarm reporting in DART protocol. - F23.04: Changed description. - F41.05: New value, 8 = Oil barrel refill - F41.09: New values, 7 = UPS functionality, 8 = Oil barrel low - F41.10: New value, 9 = Oil barrel full - Added new error codes, 49 (Illegal WIP incrementation) and 88 (UPS mode)
3.3	10.00	<ul style="list-style-type: none"> - F70.00: New access level, 7 = Brazil International - Automatic Temperature Compensation (ATC). <ul style="list-style-type: none"> - CRC's and SW versions of additional ATC related HW/SW devices are displayed as well on CRC-button press. - F01 Added ATC W&M modes (Serial and Stand Alone) - F50 Assignment of Product Type per Meter - F51 Assignment of Density per Meter - F52 Assignment of Probe # to Meter # - F53 Assignment of correction offset per Meter. - Both gross and net volume (non-temperature corrected) in totals and totalizers. - S01, S02, S05, S06, S11, S12, S15 and S16: <ul style="list-style-type: none"> Added gross volume totals and totalizers. - New error codes for ATC: 21, 22, 23, 24 & 87. - Weight & Measures Mode corrected. <p><i>More information on the ATC functionality is available in manual WM020465.</i></p>
3.4	10.01	<ul style="list-style-type: none"> - Vapour Gate VR Monitoring. <ul style="list-style-type: none"> - Alternative to FAFNIR Vaporix system. - Activated by setting F26.04 = 3. Other related parameters are F26.06-08. - System status (Timer started and Timer elapsed) reset in F47.01 = 0 (side A) and F48.01 =0 (side B). System problems (such as bad VR meter, disturbances and similar) resulting in error OFF2 will reset by itself after some minutes or when error disappear. - Same error indication on UPD's as for Vaporix VRM (OFF1, OFF2, dashes etc). - Calibration of the VR meters done in F47.09 and F48.09. Calibration tables are stored and editable in F49. - Vapour Gate Error Beep configurable in F15.04 - Vapour Gate Remote status indication configurable in F41.03 and F41.04 - A/L and other VR related results of fillings are logged in S31-S34. - F14.09 Unit Price Display decimal point indication can be set from 0-10.
3.5	10.02	<ul style="list-style-type: none"> - Added configuration of UPS action time using parameter F23.09. - Added values to F26.04, 4 (Reserved), 5 (Vapour flow Switch) and 6

Revision	Release	Description
		(Bürkert indication).
		- Added values to F41.09/F41.10, 10 (Vapour flow switch)
		- Added configuration for Physical nozzle input 4 side A in parameter F41.12.
		- Added configuration of “Pump GUI on iX” using parameter F54.01.
		- Added configuration of LED indication using parameter F54.02
		- Updated F01.00, Filling mode, to have correct value.
		- Updated F10.0N. Increase max value for Octane number
		- Updated F47/F48 to include settings for Vapour Flow Switch and Bürkert indication as well.
		- Updated S31-S34 to include Vapour Flow switch. Changed sub statistics to correct value.
		- Added Error code #48 for VRM systems.
		- Added Error code #89, Low tank level
		- Added description of ATC security switch handling in part 5.10

1.2.1 Release overview:

Release		Date (MMDDYY)	Program checksum P-xxxx
7.13		11.08.01	b912
7.15		05.21.02	cd5A
7.16		07.01.02	2232
7.17		09.11.02	5E15
7.18		09.26.02	45B0
7.19		01.21.03	175F
7.20		03.26.03	A5EE
7.21		03.27.03	B42E
7.22		05.19.03	86EC
7.23		05.23.03	2337
7.24		06.13.03	2173
7.25		07.08.03	8E22
7.26		09.26.03	813C
7.27		10.17.03	95BB
7.28		11.24.03	98C9
7.29		12.19.03	A0FD
7.30		02.27.04	D263
7.31		Not rel.	
7.32		05.07.04	A890
7.33		11.08.04	1B4A
7.34		02.21.05	FF0A
7.35		03.31.05	9F4A
7.36		04.26.05	6667
7.37		06.15.05	A4C4
7.39		17.08.05	BE6E
7.40		18.08.05	9FED
<u>1MB</u>	<u>512KB</u>		
---	7.41	01.20.06	87B6
9.00	---	02.11.06	E53B
9.01	---	04.06.06	F811
9.02	---	06.21.06	E23D
9.03	---	03.23.07	013E
10.00	---	06.11.07 (<i>Not rel.</i>)	139C
10.01	---	08.09.07	A16C
10.02	---	12.06.07	4E49

Not rel. = not released

2 Maintenance Mode Overview

2.1 General Description

You will need to access the maintenance mode in order to program functions and/or view statistics. This section explains the two ways that you can enter the maintenance mode as well as the tasks you can perform while in the maintenance mode. The function and statistics data appear in the money, volume, and unit price display windows.

2.1.1 Accessing the Maintenance Mode

Access the Maintenance Mode through one of the following interfaces:

- Service Terminal Program (STP)
- Infrared Interface

2.1.2 Performing Tasks Through the Maintenance Mode

Perform the following IGEM Operations through the Maintenance Mode:

- Configuration set-up and statistics viewing
- Diagnostics
- Remote download and upload of program code

2.2 Service Terminal Program STP

Use a laptop computer (PC) to access dispenser functions, statistics, and diagnostics. This interface can also be used to download and upload the software. The communication is through a serial link. Although you perform the programming through the pump display, a description of the various functions and statistics appear on the laptop display.

2.3 Software loading

The Software can either be loaded by a laptop (PC) as described above or by an another IGEM computer board. The communication is through the serial link. The software is loaded from the IGEM board (master) to the IGEM board in the pump.

2.4 Infrared Interface

The infrared interface has 16 buttons. Use the infrared interface to access dispenser functions and diagnostics. This interface uses only the pump display for user feedback. There is no additional display.

3 Programming IGEM

3.1 Introduction

This section discusses how to enter the maintenance mode and what functions are available for IGEM programming.

3.2 Infrared Interface

The infrared device communicates with the IGEM via an infrared link. Access the maintenance mode by pressing the CRC-push button on the computer board, upon this the program CRC values and SW Version number are indicated at the display.

If Automatic Temperature Compensation (ATC) is activated, the CRC's and SW versions of related additional HW/SW devices (CAN-ISB board and TM-board) will be displayed as well one after the other.

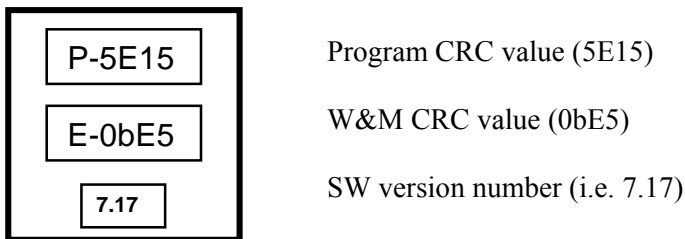

After the CRC values are cleared, press one of the following keys within 20 sec.:

ENTER	Field service engineer entry using field engineer password
1	Station manager entry using station manager password
2	Operator entry using operator password
3	Read program CRC checksums
CLEAR	Weights and Measures entry using weights and measures password

The maintenance mode asks you for a password twice before allowing access to the maintenance mode functions and statistics. A 10 second time-out is built into the password entry code.

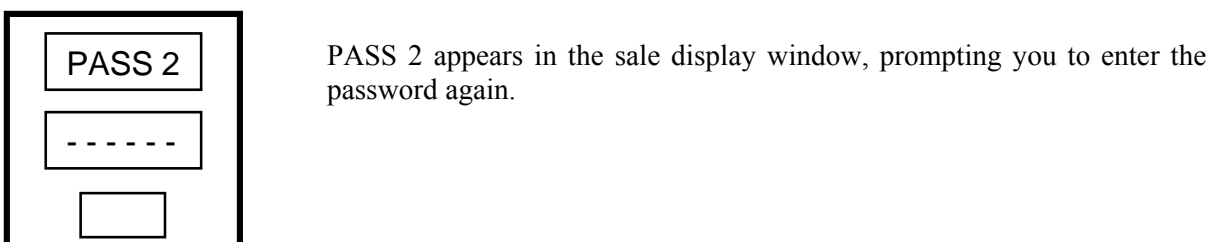
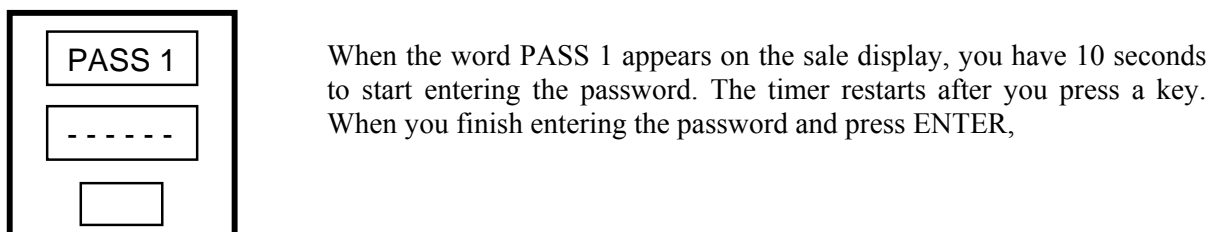

3.3 Service Terminal Program STP

Field service engineers can use a laptop computer to run the service terminal program (STP). To run the STP, perform the following steps:

Remove the dispenser bezel.

1. Connect the serial data cable to the serial channel of the laptop and the serial channel on the iGEM computer board. Make sure that the straps to select the link type are set correctly.
2. Start the STP (SERVTERM.EXE).
3. Select type of Hardware interface by pressing the "TYPE" button
4. Establish the communication by pressing the CRC-button on the computer board.
When communication is established iGEM enters maintenance mode.

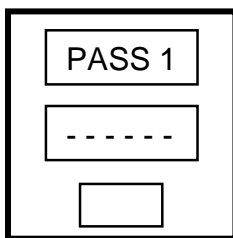

When PASS 1 appears on the sale display, enter the field service engineer password and press ENTER.

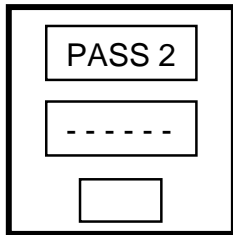

When PASS 2 appears in the sale display window, enter the password again, then press ENTER.

3.4 Maintenance Mode Display

When you enter the maintenance mode, the unit price display windows show "F - - ", the money display window shows the software version number, and the volume display window shows the date of the software version. This is the start of the function programming mode.

To edit or view specific functions, enter any function number using the number keys and press ENTER. The corresponding number appears in the money display window.

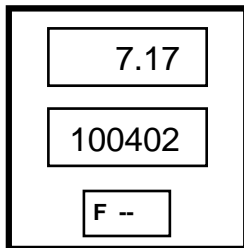

Software Version or Release number, (i.e. 7.17)

Date (MMDDYY, i.e. 04. April 2002)

To enter the statistics viewing mode press either the UP or DOWN arrow when the unit price is displaying "F - - ". When you enter the statistics viewing mode, the unit price display window shows "S - - ", the money display window shows the current transaction count for side B, and the volume display window shows the current transaction count for side A.

To view specific statistics, enter any statistic number using the number keys and press ENTER. The corresponding number shows in the money display window.

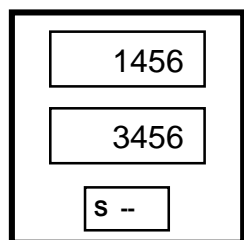

i.e. 1456 fillings on side B

i.e. 3456 fillings on side A

3.5 Maintenance Mode Exit

There are two ways that you can exit the maintenance mode:

- Exit and Save Changes
- Quick Exit

3.5.1 Exit and Save Changes

Use Function 00 - Exit Function to exit the maintenance mode and save changes. When you are in the function, Enter 3 for the sub function, then press ENTER twice. See F00 - Exit Function for more information on the Exit Function. If you entered maintenance mode using the infrared interface, the maintenance mode becomes inactive. If you entered maintenance mode using the Service Terminal Program, the maintenance becomes idle, but will still be active until you remove the cable from the interface or terminate the Service Terminal Program.

3.5.2 Quick Exit

If you use a Quick Exit, you will lose changes you have made. To perform a Quick Exit, do the following:

- If you used the Service Terminal Program to enter the maintenance mode, deactivate the maintenance mode by removing the cable from the RS232 interface or terminate the Service Terminal Program.
- If you used the Infrared Interface, press the CLEAR key until the unit price display windows shows "F - - " or "S - -". Then press ENTER three times. This causes the maintenance mode task to immediately terminate.

3.6 Function or Statistic Entry Level

You must access all function and statistic data through sublevels before you can view or write any data. The initial display shows dashes on the money display, the volume display is blank, and the unit price display shows the function or statistic number. The function or statistic number is preceded by an F or an S. Functionality for this screen is defined as follows:

Button	description
CLEAR	Returns control to initial screen.
ENTER	Opens the first sublevel to which you have access.
UP	Advances to the next function or statistic
DOWN	Returns to the previous function or statistic
#	Ignored.
NEXT	Advances to the next function or statistic
NUMBER (1-9)	Goes to function or statistic number entered. If the number is beyond the range of the available functions or statistics, the maximum function or statistic is used. When you begin to enter numbers, the non-numeric keys have the following functionality:
CLEAR	Backspace key if there is numeric input, otherwise returns control to initial screen.
ENTER	Accepts any numeric input already entered, otherwise opens the first sublevel to which you have access.
UP	Ignored when numeric input has been entered, otherwise advances to next function or statistic.
DOWN	Ignored when numeric input has been entered, otherwise returns to previous function or statistic.
NEXT	Ignored when numeric input has been entered, otherwise advances to next function or statistic
#	Ignored
NEXT	Ignored when numeric input has been entered, otherwise returns to previous function or statistic.
CLEAR	If you press the CLEAR key before you enter numeric data, the system will not accept the numeric data, because it has returned to the initial screen.

3.7 Sub Entry Level

When you enter the sub entry level, the unit price display shows the function/statistic number in the two left-most digits and the sub level number in the two right-most digits separated with a decimal point. The F or S no longer appears. The following list shows functionality provided at this level. Not all functionality is available depending on user access.

Button	Description
CLEAR	Returns control to the function or statistic entry level screen.
UP	Increases the value of the displayed parameter; value rolls over when the maximum value is reached.
ENTER	Returns control to the function or statistic entry level screen.
DOWN	Decreases the value of the displayed parameter; value rolls over when the minimum value is reached.
#	Clears the money display and allows you to enter a new value for the given parameter. Out of range values are ignored.
NEXT	Advances to the next sub function or sub-statistic within the current function or statistic.
NUMBER (1-9)	If you enter numeric data without first pressing the # key, the system goes to the sub function or sub-statistic of the corresponding number that you entered. If the number is beyond the range of available sub-functions or sub-statistics, the maximum sub function or sub-statistic is used. When you begin to enter numbers (preceded by the # key or not), the non-numeric keys have the following functionality.
CLEAR	Backspace key if there is numeric input, otherwise returns control to initial screen.
ENTER	Accepts any numeric input already entered.
UP	Ignored when numeric input has been entered, otherwise returns control to the sub entry level.
DOWN	Ignored when numeric input has been entered, otherwise returns control to the sub entry level.
#	Ignored when numeric input has been entered, otherwise returns control to sub entry level.
NEXT	Ignored when numeric input has been entered, otherwise returns control to the sub entry level.

3.8 Function List

The software controls access to functions and sub-functions. It contains an access level table that determines what functions each user has access to. Access levels are as follows:

- Read and Write
- Read only
- No access

3.8.1 F00 - Exit Function

Use this function to select one of three maintenance mode exits.

Sub-function numbers are in the format '.0X' where X = the selected configuration parameters defined as follows:

.00 Exit Option, 1 through 3

1 = Do not exit and do not save changes

2 = Exit, but do not save changes

3 = Exit and save changes

4 = Soft cold-start, PASS appears in the money display, enter Password and ENTER to get the cold-start executed

3.8.2 F01 - Filling Modes

Sub-function numbers are in the format '.0X' where X = the selected configuration parameters defined as follows:

.00 Filling Mode, 1 through 6

1 = Serial Mode, dispenser controlled by site controller via serial link

2 = Stand Alone Mode, dispenser not supervised by a site controller

3 = Serial W&M Mode, same as #1, but 3 volume decimals (.xxx volume units) ***Non-temperature compensated.***

4 = Stand Alone W&M Mode, same as #2, but 3 volume decimals (.xxx units) ***Non-temperature compensated.***

5 = Serial ATC W&M Mode. Displaying ATC related data.

6 = Stand Alone ATC W&M Mode. Displaying ATC related data.

NOTE! Flow loss check (on high-speed blenders) is disabled in any of the W&M modes.

See chapter: Pumping unit flow lost check to avoid dry operation when two meters are assigned to one nozzle

3.8.3 F02 - Clock Configuration

Sub-function numbers are in the format '.0X' where X = the selected configuration parameters defined as follows:

.00 Time in the format HH.MM

.01 Date in the format MM.DD

.02 Year in the format YY.YY

3.8.4 F03 - Set Side A Unit Prices

The Unit Prices are initialised after Coldstart to 9901, 9902, 9903, 9904.

Sub-function numbers are in the format:

.0N Set prices

.1N Not used (Set cash prices)

N Logical nozzle number 1-4 (5-8 optional)

3.8.5 F04 - Set Side B Unit Prices

The Unit Prices are initialised after Coldstart to 9911, 9912, 9913, 9914.
This function provides the same functionality on side B as F03

3.8.6 F05 - Set Side A Fuelling Point Address

.00 Fuelling Point Address, 1 through 99, where 0 = None Assigned

3.8.7 F06- Set Side B Fuelling Point Address

.00 Fuelling Point Address, 1 through 99, where 0 = None Assigned

3.8.8 F07 - Dispenser Configuration

Sub-function numbers are in the format '.0X' where X = the selected configuration parameters defined as follows:

- .00 Maximum logical nozzle number for each side, 1-4 (5-8 optional), read only see F37.01
- .01 Dispenser geometry, 1 = single sided, 2 = double sided, read only see F37.02
- .02 Maximum blend error allowed, 1-5 (units of %). *For Oil mix the value is in %.*
- .03 First check set for blending if litres, 2-200 (units of 1/10 Litres)
- .04 First check set for blending if gallons, 5-50 (units of 1/10 Gallons)
- .05 Number of Dispenser Displays per side
 - 0 = one Display per side
 - 1 = second Display on side A
 - 2 = second Display on side B
 - 3 = second Display on side A and side B
- .06 Wayne Integrated Pulsar (WIP) Type
 - 1 = serial WIP
- .07 Stop button configuration
 - 1 = Stop Both Sides
 - 2 = Stop Side
- .08 Stop button assignment
 - 0 = Stop Button input on display keyboard input disabled (but remains on original stop button input display connector J4)
 - 1 – 24 = used button number on display keyboard input

3.8.9 F08- Side A Dispenser Type Configuration Part #1

Sub-function numbers are in the format: '.XN' where X = the selected configuration parameters and N = the logical nozzle number 1-4 (5-8 optional) as follows:

.0N Physical nozzle number assignment, 0-4, 0 = None, (5-8 optional)

.1N	Product type assignment,	1-6, 1 = Normal + high-speed 2 = blend 3 = LPG 4 = 40-90 (double sided pump) 5 = Oil mix 6 = AdBlue
.2N	Unit Price display assignment,	0-4, 0 = None, (5-8 optional)
.3N	Primary meter number assignment,	0-8, 0 = None, (9-16 optional)
.4N	Secondary meter number assignment,	0-8, 0 = None, (9-16 optional)
.5N	Primary valve number assignment	0-10, 0 = None, (11-16 optional)
.6N	Primary valve type,	1-3 1 = ASCO On/Off 2 = Skinner Prop. (Not used) 3 = ASCO Proportional 4 = Two-stage (fast flow)
.7N	Secondary valve number assignment,	0-10, 0 = None, (11-16 optional)
.8N	Secondary valve type,	1-3, (refer to .6N prim. valve type) (4 = Two-stage slow flow)
.9N	Third valve number assignment,	0-10, 0 = None, ASCO on/off only

3.8.10 F09 - Side B Dispenser Type Configuration Part #1

This function provides the same functionality on side B as F08

3.8.11 F10 - Side A Dispenser type Configuration Part #2

Sub-function numbers are in the format: '.XN' where X = the selected configuration parameters and N = the logical nozzle number 1-4 (5-8 optional).

.0N	Octane number,	0-110, 0 = None assigned
.1N	Product select button input number,	1-24, 0 = None assigned
.2N	Push-to-Start button input number,	1-24, 0 = None assigned
.3N	Vapour recovery system enabled,	1 = Yes, 2 = No
.4N	Beep annunciation in a series of six beeps on physical nozzle lift,	1 = Yes, 2 = No
.5N	High/Low flow (80/40l/min) capacity Toggle between flow at F29/30.2x and F29/30.3x	1-24, 0 = None assigned
.6N	High capacity button assignment (iGEM keyboard = 10) Flow at F29/30.3x	1-24, 0 = None assigned
.7N	Low capacity button assignment (iGEM keyboard = 9) Flow at F29/30.2x	1-24, 0 = None assigned
.8N	Grade code assignment <i>0 = grade code as Log. Nozzle no.</i>	(0 - 9),

	<i>possible grade codes for Ferranti CL</i>	0 - 9	
	<i>possible grade codes for LJCL</i>	1 - 5, where 1 = grade 0 etc, 0 = not assigned	
	<i>possible grade codes for DART</i>	1 - 7	
.9N	Maximum volume limit 1-6 digits	0-999999	0 = None assigned

3.8.12 F11 - Side B Dispenser Type Configuration Part #2

This function provides the same functionality on side B as F10

3.8.13 F12 - Side A Pump Assignments

Sub-function numbers are in the format: '.XN' where X = the selected configuration parameters and N = the logical nozzle number 1-4 (5-8 optional).

.0N	Primary pump assignment,	0-4,	0 = None (5-8 optional)
.1N	Secondary pump assignment,	0-4,	0 = None (5-8 optional)
.2N	Third pump assignment,	0-4,	0 = None (5-8 optional)

3.8.14 F13 - Side B Pump Assignments

This function provides the same functionality on side B as F12

3.8.15 F14 - Dispenser Display Configuration (both sides)

Sub-function numbers are in the format '.0X' where X = the selected configuration parameters defined as follows:

.00	Number of unit price displays per side,	0-8,	0 = None supported
.01	Display mode after sale paid 1 = Money is actual, volume is actual, unit price is actual 2 = Money is zeros, volume is zeros, unit price is actual 3 = Money is zeros, volume is zeros, unit price is blanks 4 = Money and Volume actual, Unit Price blank 5 = Money is actual, volume is actual, unit price is for 5sec. actual		
.02	Money display digits right of decimal point,	0-4	
.03	Volume display digits right of decimal point,	0-4	
.04	Unit Price display digits right of decimal point, (used as base for the money calculation)	0-4	
.05	Flash unit price display when selected - after 8 - blanks 3 = flash always	1 = No Flash, 2 = Flash until flow	
.06	Suppress display of leading zeros in normal mode	1 = Yes	2 = No
.07	Totals and totalizer amount display digits right of the decimal point, <i>(has to be set to 2 for ATCL, DART and LJCL totals to be correct)</i>	0-4	

- .08 Totals and totalizer volume display digits right of the decimal point, 0-4
(has to be set to 2 for ATCL, DART and LJCL totals to be correct)
- .09 Unit Price display decimal point indication digits right of decimal point, (to be used only when the indicated decimal point shall differ from the setting in F14.04). i.e. Germany = 1.
0 – 4, forced decimal position regardless of F14.04.
5 = disabled = use setting in 14.04.
6 – 10, forced decimal position regardless of F14.04 (6 = 0 decimals, 7 = 1 decimal and so on).
Used when running against S&B POS running IFSF LON with iGEM SW version 10.01 or newer..

3.8.16 F15 - Dispenser Annunciator Configuration

Sub-function numbers are in the format '.0X' where X = the selected configuration parameters defined as follows:

- | | | | |
|-----|--|---------|--------|
| .00 | Beep annunciator on any button push | 1 = Yes | 2 = No |
| .01 | Beep annunciator on physical nozzle lift | 1 = Yes | 2 = No |
| .02 | Repeat annunciator beep if physical nozzle out and Push-to-start (or grade select) NOT satisfied | 1 = Yes | 2 = No |
| .03 | Beep annunciator once for each eight's, blanks, and zeros | 1 = Yes | 2 = No |
| .04 | Five short beeps in series on nozzle return when Vapour Gate VRM timer is activated. | 1 = Yes | 2 = No |

3.8.17 F16 - WIP Configuration

Sub-function numbers are in the format '.0X' where X = the selected configuration parameters defined as follows:

- .00 Measurement mode
1 = Litres
2 = Gallons
3 = Imperial Gallons
- .01 WIP reverse pulse hysteresis, 1-64 default = 2
- .02 Confirm WIP serial number change (when WIP has been replaced)
0 = Serial number stored
1 = Confirm new serial WIP numbers (needs to be done when WIP has been replaced and F16.04=1, this parameter will be automatically reset when Maintenance Mode is exited and new serial number is stored)
- .03 Reverse pulse Limit (after hysteresis) on an idle/unused WIP, 1-255
- .04 Verify WIP serial number change 0 = disabled 1 = enabled
- .05 Download calibration factor (8320) to WIP if product type = LPG by F08/09.1N=3
0 = disabled 1 = enabled
- .06 Reserved.

3.8.18 F17 - Dispenser Limits Configuration

Sub-function numbers are in the format '.0X' where X = the selected configuration parameters defined as follows:

.00	Maximum number of pulse errors on an "in use" WIP (in a transaction),	1-99
.01	Maximum number of pulse errors on an idle/unused WIP,	1-99
.02	Maximum number of display errors/filling,	0-99, 0 = disabled
.03	Stop for "no flow" or "flow lost" time limit	0 - 1000 seconds
.04	Maximum number of consecutive no flow events without error,	0-10, 0 = disabled
.05	Maximum number of flow lost events w/out error,	0-10, 0 = disabled
.06	Maximum number of unfinished fillings,	0-10, 0 = disabled
.07	Maximum filling amount/filling,	1-6 digits, 0 - 999999
.08	Maximum volume amount/filling,	1-6 digits, 0 - 999999

3.8.19 F18 - Blend Ratio Configuration

Sub-function numbers are in the format: 'SN' where S = the Side number (1=A, 2=B) and N = the logical nozzle number 1-4 (5-8 optional).

SN.	Blend ratio (the allowed range for data is 0-101)
	100 = primary valve only, secondary valve closed
	0 = secondary valve only, primary valve closed
	101 = primary and secondary valve assignment (high capacity pumps 130 l/m)

3.8.20 F19 - Volume Unit Specific Configuration

Sub-function numbers in the format '.VX' where V= volume unit selection (1= litres, 2=gallons) and X = the selected configuration parameters defined a follows.

.10	Suppressed volume @ start of filling,	0-9 cl.
.11	Maximum volume for selection of new product,	0-9 cl.
.12	Suppress overflow of preset limit,	0-99 cl.
.13	Preset/Prepay slow down volume delta.	5-399 cl.
.14	Forward pulse limit on idle/unused WIP.	1-99 cl.
.15	Second Clear volume limit	1-15 cl, 0 = disabled.
.16	Hose test volume,. (Set time in F23.06)	1-25 cl, 0 = disabled
.17	Pulses/litre configuration on spare outputs 1-4 (<i>pulse width = 2,1ms, max flowrate > 130 lpm</i>)	1 = 1 cl per pulse 10 = 10 cl per pulse 100 = 100 cl per pulse
	Pulses/litre configuration on spare outputs 1-4 (<i>pulse width = 3,75ms, max flowrate 80 lpm</i>)	101 = 1 cl per pulse 110 = 10 cl per pulse

200 = 100 cl per pulse

.20	Suppressed volume @ start of filling,	1-99 (units of 1/1000 Gallons)
.21	Maximum volume for selection of new product,	1-99 (units of 1/1000 Gallons)
.22	Suppress overflow of preset limit,	0-99 (units of 1/1000 Gallons)
.23	Preset/Prepay slow down volume delta.	2-999 (units of 1/1000 Gallons)
.24	Forward pulse limit on idle/unused WIP.	1-999 (units of 1/1000 Gallons)
.25	Second Clear volume limit	0-4 cg, 0 = disabled.
.26	Hose test volume. (Set time in F23.06)	0-65 cg, 0 = disabled
.27	Pulses/gallon configurations on spare outputs 1-4	<i>outputs pulses/litre</i>

3.8.21 F20 - Dispenser Serial Link Configuration

Sub-function numbers are in the format '.0X' where X = the selected configuration parameters defined as follows:

- .00 Protocol
- 0 = Off link
 - 1 = Standard DART
 - 2 = FULL DART
 - 3 = FULL DART for IFSF LON (for DART/IFSF protocol converter board)
 - 4 = US current loop,
 - 5 = Ljungmans current loop
 - 6 = Ferranti A
 - 7 = ATCL
 - 8 = Ferranti B
 - 9 = Ferranti C (copos)
 - 10 = IFSF Stand Alone Mode (special DART mode)
 - 11 = Nuovo Pignone current loop (SINP)
 - 12 = Nuovo Pignone protocol on RS485
 - 13 = IFSF LON (for iGEM piggyback board, cycle power after saved change)
 - 14 = IFSF LON Stand Alone
- .01 Baud rate
- 1 = 1200
 - 2 = 2400
 - 3 = 4800
 - 4 = 9600
 - 5 = 19200
 - 6 = 38400
- 9600 is default
- NOTE1: DART and Ljungmans current loop is approved on 9600 Baud only
- NOTE2: When running IFSF LON Baud rate is automatically set to 76800 (not reflected in this parameter)
- .02 Reserved

- .03 Always enter FILLING COMPLETE on nozzle return (including on grade change).
1 = Yes 2 = No
- .04 Use logical nozzle Totals/Totalisers Statistics as grade Totals/Totalisers Statistics
1 = Yes, statistics will be updated based on grade code assigned by F10/11.8N
2 = No, statistics will be updated based logical nozzle numbers
- .05 Alarm reporting in Dart protocol
1 = Report alarm on occurrence and all alarms on status request. Alarms reset by RESET command.
2 = Report alarm at end of filling (only last alarm that occurred). *Default.*

Physical link type configuration (1. Generation of iGEM Boards)

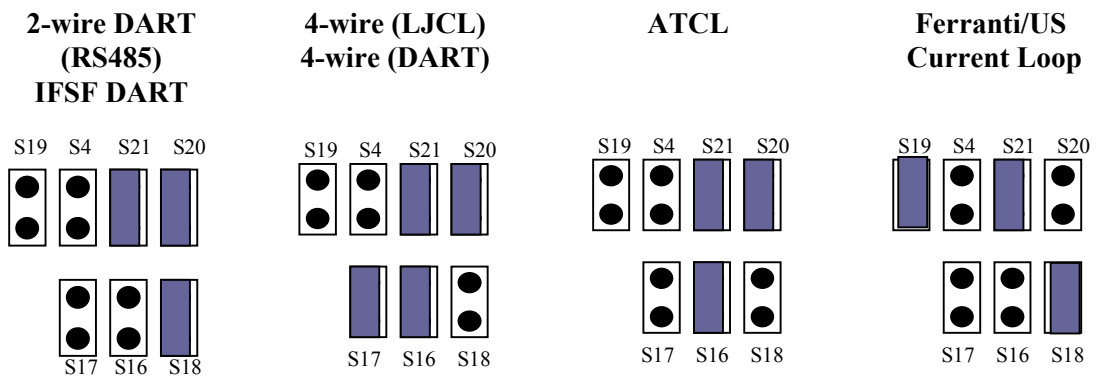

Physical link type configuration (2. Generation of iGEM Boards)

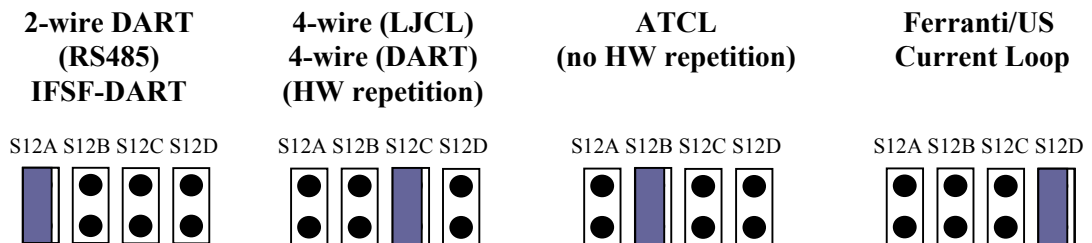

3.8.22 F21 - Miscellaneous Configuration

Sub-function numbers are in the format '.0X' where X = the selected configuration parameters defined as follows:

- .00 Pump Motor ON configuration
1 = ON at end of display test
2 = ON at start of display test, to be used on dispensers (submersible operated) set delay time in F23.00
3 = ON at product selection
- .01 Access to F01: filling mode configuration 1 = Yes 2 = No
- .02 Standalone indication enabled 1 = Yes 2 = No
(show four digits right of decimal point)

- .03 Blank or dash unselected unit price displays on product selection 1 = Blank 2 = Dash
- .04 Product change allowed after fuelling started 1 = Yes 2 = No
- .05 Electro-mechanical totalizer configuration and
- 1 = One EMT per meter. EMT 1 on J6 is mapped to meter 1 and EMT5 on J7 is mapped to meter 5.
 - 2 = One EMT per WIP/GHM. EMT 1 on J6 is mapped to WIP 1 and EMT 4 on J6 is mapped to WIP 4.
 - 3 = One EMT per logical nozzle. EMT 1 on J6 is mapped to logical nozzle 1 on side A and EMT 5 on J7 is mapped to logical nozzle 1 on side B.
Note! Maximum 4 logical nozzles per side.
 - 4 = One EMT per logical nozzle following electronic totals behaviour. EMT 1 on J6 is mapped to logical nozzle 1 on side A and EMT 5 on J7 is mapped to logical nozzle 1 on side B.
Note! Maximum 4 logical nozzles per side.
- .06 Flow Rate Indication while filling at the amount display
- 0 = Disabled
 - 1 = show primary volume
 - 2 = show secondary volume
 - 3 = show primary plus secondary volume
 - 4 = show primary volume at the amount display and secondary volume at the unit price display
 - 5 = same as "1", function enabled if "crc-button" is pressed before filling, flow rate indicated for 10sec. if button "7" is pressed while filling
 - 6 = same as "2", function enabled if "crc-button" is pressed before filling, flow rate indicated for 10sec. if button "7" is pressed while filling
 - 7 = same as "3", function enabled if "crc-button" is pressed before filling, flow rate indicated for 10sec. if button "7" is pressed while filling
 - 8 = same as "4", function enabled if "crc-button" is pressed before filling, flow rate indicated for 10sec. if button "7" is pressed while filling
- .07 Error/Event indication at the pump display
- 0 = flash display and show "CLOSED" from error level C
 - 1 = flash display only from error level B
 - 2 = flash display, show "CLOSED" and show the error code on the unit price display from error level C
 - 3 = flash display and show the error code on the unit price display from error level B
- .08 Weight and Measures Totalizer or Totals indication at the pump display and transmission to the site controller (activated by Remote Control CLEAR button)
- 0 = Totalizer per meter
 - 1 = Totalizer per logical nozzle
 - 2 = Totals per meter
 - 3 = Totals per logical nozzle
 - 4 = WIP Totalizer *Totals (as if set to 2 or 3) are sent via POS.*
- .09 Maintenance Mode access through Remote Control without pressing the CRC button on the IGEM computer first
- 0 = entry possible at all levels
 - 1 = entry with button 1, 2, 3, CLEAR. But not ENTER CRC button needs to be pressed first

- 2 = entry with button 3, CLEAR. But not ENTER, 1, 2 CRC button needs to be pressed first
- 3 = entry with button 3 and CLEAR. But not ENTER, 1, 2, CRC button needs to be pressed first
- 4 = no entry without pressing the button first

3.8.23 F22 - Sales Amount Calculation

Sub-function numbers are in the format '.0X' where X = the selected configuration parameters defined as follows:

- .00 Denomination ratio between Money display and Unit Price display
 - 1 = 1/1 (money = 1 x unit price)
 - 2 = 10/1 (money = 10 x unit price)
 - 3 = 100/1 (money = 100 x unit price)
 - 4 = 1/10 (money = unit price / 10)
 - 5 = 1/100 (money = unit price / 100)
 - 6 = 1/1000 (money = unit price / 1000)
- .01 Count by ones or fives in least significant digit of Money display
 - 1 = Ones
 - 2 = Fives
- .02 Volume digits to the right of the decimal point used in amount calculation 0-5, where 5 = use volume decimal point as defined in function 14.03.
- .03 Money preset configuration.

As the unit price increases, the system reaches a point when certain preset money amounts cannot be set due to the resolution of the metering system and/or the configured resolution of the volume used for the money calculation. Program this sub-function to give the desired result when this occurs.

 - 0 = Calculate the closest volume from the money and the unit price and show the actual money amount at the end of the sale.
 - 1 = Calculate the closest volume from the money and the unit price but show the preset money amount at the end of sale as long as the sale hasn't reached the maximum overrun volume.
 - 2 = Calculate a volume amount that will ensure a money amount that is greater than or equal to the preset amount and show the preset money amount at the end of the sale as long as the sale hasn't reach the maximum overrun volume (recommended).
 - 3 = Calculate a volume amount that will ensure a money amount that is greater than or equal to the preset amount and show the actual amount at the end of the sale.
- 04 Money rounding method
 - 0 = money value is rounded up, if rounding digit is greater or equal to 5 (i.e. 21,2350 -> 21,24)
 - 1 = round to even, money value is rounded up only if value is odd and rounding digit is greater or equal to 5. (i.e. 21,2350 -> 21,24, 21,2450 -> 21,24)

3.8.24 F23 - Miscellaneous Timers

Sub-function numbers are in the format '.0X' where X = the selected configuration parameters defined as follows:

.00	Display test time (total test time - also known as valve on delay time for dispensers – submersible operated),	2-24 (units of 1/2 Sec)
.01	Minimum time between fillings (nozzle In timeout) (units of 1/2 Sec), nozzle WILL NOT be recognised when timeout ends nozzle WILL be recognised when timeout ends (offset of 20, f.e. 24 = 2 seconds)	0 = disabled 0-20, 21-40
.02	Stop for offline error, (seconds),	0-60 0 = disabled
.03	Maximum time allowed for filling (minutes),	0-60, 0 = disabled
.04	Time from unit price change until next start of sale. Will delay nozzle lift response this amount of time.	0-15 sec
.05	High/Low flow (80/40l/min) capacity and Master/Satellite selection timeout (seconds)	0-60
.06	Hose test time (units of 1/2 Sec.), - before filling - controlled via LJCL/DART, - after filling (for France)	0-10 0 = disabled 11-20 (= 0,5 - 5 sec) 21-30 (= 0,5 - 5 sec)
.07	LPG nozzle timeout (units of sec.) used when valve type assigned by F08/09.1N = 3 = LPG	1-15
.08	COPOS Display Timeout (seconds)	0-60 0 = disabled
.09	UPS action time (minutes)	20-60

3.8.25 F24 - Local Preset Configuration

Sub-function numbers are in the format '.0X' where X = the selected configuration parameters defined as follows:

.00	Operation Mode 1 = Money amount only entry 2 = Volume amount only entry 3 = Default to money, toggle by button 4 = Default to volume, toggle by button	
.01	Preset entry required before filling start	1 = Yes 2 = No
.02	Preset Keyboard type and US preset fill mode display 0 = preset disabled, the buttons are used for other appl.s (f. e. Prod. select on a Single hose pump) 1 = 5 button preset keyboard, displaying blanks (“ “) 2 = 12 button preset keyboard, displaying blanks (“ “)- (button 6= soft key 1, button 12= soft key 2) 3 = 5 button preset keyboard, displaying dashes (“-----“) 4 = 12 button preset keyboard, displaying dashes (“-----“) 5 = 5 button preset keyboard, displaying fill (“FILL“)	

	6 = 12 button preset keyboard, displaying	fill (“FILL“)
	7 = 5 button preset keyboard, displaying	preset (“PrESEt“)
	8 = 12 button preset keyboard, displaying	preset (“PrESEt“)
	9 = 5 button preset keyboard, ARAL application, preset value is not indicated at the display, instead a LED beside the preset button is lit for identification,	
.03	Preset entry time-out, (seconds)	0-180
.04	Soft key #1 function configuration,	0-10
	0 = Disabled	
	1 = Select Money Pre-set	
	2 = Select Volume Pre-set	
	3 = Toggle between Money or Volume Pre-set	
	4 = Select FILL Mode	
	5 = Select Pre-set Value #1	
	6 = Select Pre-set Value #2	
	7 = Select Pre-set Value #3	
	8 = Clear Key	
	9 = Enter Key	
	10 = Select Pre-set Value #4	
.05	Soft key #2 function configuration, (See .04 for definitions of configuration items.)	0-10
.06	Soft key #3 function configuration, (See .04 for definitions of configuration items.)	0-10
.07	Soft key #4 function configuration, (See .04 for definitions of configuration items.)	0-10
.08	Soft key #5 function configuration, (See .04 for definitions of configuration items.)	0-10
.09	First display digit entry point for money preset,	1-6
.10	First display digit entry point for volume preset,	1-6

3.8.26 F25 - Local Preset By Button Configuration

Sub-function numbers are in the format '.0X' where X = the selected configuration parameters defined as follows:

.00	Preset value #1 operation mode	1 = Money	2 = Volume
.01	Preset value #2 operation mode	1 = Money	2 = Volume
.02	Preset value #3 operation mode	1 = Money	2 = Volume
.03	Preset value #4 operation mode	1 = Money	2 = Volume
.04	Preset value #1 money/volume limit,	0-999999	
.05	Preset value #2 money/volume limit,	0-999999	
.06	Preset value #3 money/volume limit,	0-999999	
.07	Preset value #4 money/volume limit,	0-999999	

3.8.27 F26 - VAP Configuration

Sub-function numbers are in the format '.0X' where X = the selected configuration parameters defined as follows:

- .00 Buerkert vapour recovery control
 - 0 = Disabled
 - 1 = generate pulses l/min (no nozzle information)
 - 2 = generate pulses l/min and nozzle information
- .01 Manual Calibration without the Buerkert Handterminal
 - 0 = Disabled
 - 1 = Enabled (Swedish Application)
- .02 K-factor 1 (V/L) used for manual calibration.
Default = 107 (Buerkert + ASF Pump)
- .03 K-factor 2 (general) used for manual calibration.
Can be used to adjust the overall vapour regulation.
Default = 100.
- .04 Vapour recovery monitoring configuration.
 - 0 = Disabled
 - 1 = FAFNIR VAPORIX Enabled, show monitoring errors on pump display only (connect Vaporix System to expansion interface pulse and error signals)
 - 2 = FAFNIR VAPOIRX Enabled, show monitoring errors on pump display and transmit via DART to System
Attention, make sure that System has been loaded with specific Software Version to handle the DART Alarmcodes.
 - 3 = Wayne VAPOUR GATE Enabled, show monitoring errors on pump display and transmit via DART to System.
 - 4 = Reserved
 - 5 = Vapour Flow Switch. Show monitoring errors on display LED if configured so.
 - 6 = Bürkert LED indication. Show monitoring errors on display LED if configured so.
- .05 Dry test
 - 0 = Disabled
 - 1-25 = Duration time in seconds.
- .06 Vapour Gate meter averaging time
1-5 seconds (default 5)
- .07 Vapour Gate VRM Shut down timer. Activated on 10 consecutive erroneous VRM fillings.
 - 0 = Disabled
 - 1 - 250 = Duration time in hours (default 72 hours).
- .08 Vapour Gate Flow data on Display
 - 0 = Disabled
 - 1 = Vapour Volume displayed on Money display
 - 2 = Vapour Flow rate displayed on Money display
NOTE! If fuel flow rate is set to be displayed (F21.06 > 0) then, fuel flow rate is displayed in Volume display instead.

3.8.28 F27 - Side A Dispenser Configuration

.00	Button input for local authorise function,	0-24, 0 = disabled
.01	Cash button assignment,	0-24, 0 = disabled
.02	reserved	
.03	reserved	

3.8.29 F28 - Side B Dispenser Configuration

This function provides the same functionality on side B as F27

3.8.30 F29 - Side A Litre Flow Rate Configuration

.0N	Maximum slow flow rate, (units of 1/10 litres/min.)	3-50
.1N	reserved (Minimum slow flow rate)	
.2N	Maximum fast flow rate, (units of litres/min.)	10-180
.3N	Maximum full flow rate (units of litres/min.) (to be used for flow selection by button -40/80 l/min.)	10-180

N Logical nozzle

3.8.31 F30 - Side B Litre Flow Rate Configuration

This function provides the same functionality on side B as F29

3.8.32 F31 - Side A Gallon Flow Rate Configuration

.0N	Maximum slow flow rate, (units of 1/10 Gallons/min.)	1-10
.1N	reserved Minimum slow flow rate,	
.2N	Maximum fast flow rate, (units of Gallons/min.)	3-48
.3N	Maximum full flow rate (units of Gallons/min.) (to be used for flow selection by button -10/20 Gallons/min.),	0-48

N Logical nozzle

3.8.33 F32 - Side B Gallon Flow Rate Configuration

This function provides the same functionality on side B as F31

3.8.34 F33 - Password Change

Dashes appear in the money display window, and the word PASS appears on the volume display. When you begin editing, the money display goes blank and dashes appear instead of the regular entries. Enter the new password twice. The sub-function numbers are defined as follows:

.00	Service Engineer Password,	max. of 6 numbers
.01	Station Manager Password,	max. of 6 numbers
.02	Station Operator Password,	max. of 6 numbers
.03	Weights and Measures Password,	max. of 6 numbers

3.8.35 F34 - Diagnostics

These functions provide a way to test various parts of the hardware, including all switches, displays, beeper and vapour recovery. Other motors and valves are not available for security and safety reasons. When a test is invoked, press CLEAR or ENTER to end the test.

- .01 Switch test.
The money display shows 4 dashes until a switch is activated. A description of the activated switch and side (1 or 2) is displayed on the money display. For example, nozzle switch 3 on side 2 is displayed as 2n3 as long as the switch is depressed (n = nozzle, S = Stop switch, b = bitbus e.g. preset, high/low flow, satellite buttons,).
When the nozzle is deactivated the display reverts to dashes.
 - .02 Display test . A "walking segment" test is performed in which each segment of the display is turned on and off. Each digit of the display is tested at the same time.
 - .03 Vapour Recovery test, Side A
 - .04 Vapour Recovery test, Side B
- These sub-functions simulate a flow rate to the vapour recovery system, which turns on the recovery motor accordingly. Lift the nozzle on the specified side to start the test. The volume display shows the simulated flow rate. The UP key increases the simulated flow rate. The DOWN key decreases the flow rate in steps of 1l/min.

3.8.36 F35 = Side A Satellite Configuration

Sub-function numbers in the format '.XN' where N = the logical nozzle number 1-4 (5-8 optional) and X = the selected configuration parameters defined as follows:

- .00 Satellite Nozzle, logical nozzle no. 0-4 (5-8 opt.), 0 = None
- .01 Master Nozzle, logical nozzle no. 0-4 (5-8 opt.), 0 = None
Both SAT and Master nozzle has to be assigned on SAT pump
- .02 Satellite Enable Button, Button no. 0-24, 0 = None
(0 = start filling on SAT or Master without any button press before)
- .03 Master Enable Button, Button no. 0-24, 0 = None
If no button is assigned, flow will be re-directed within the timeout F23.05 based on nozzle lift/returned.
- .04 Satellite behaviour
0 = Limited (can't start on SAT nozzle, no dual nozzle filling e t c).
1 = Can not start on satellite, dual and sequential filling possible
2 = Full (any combinations).
3 = start filling on Master or SAT, simultaneous not allowed
- .05 Single Meter SAT, 0 = Disabled. 1 = Enabled
(one meter with duplex valve 1 and 9).

3.8.37 F36 = Side B Satellite Configuration

This function provides the same functionality on side B as F35

3.8.38 F37 - Pump Model Configuration

Setting the pump model number will write the default values specified for the specific model. Default values will always be written to F07, 08, 09, 10, 11, 12, 13, 18, 29, 30, 31, 32, 35, and 36. **Make sure that you always select the pump model number first before setting a specific function. Any change to the model number will overwrite previous settings of the above Function registers!** Enter pump model number (01-99) to be configured:

- .00 model number
see iGEM Template Models document (#WM005547)

- | | | |
|-----|--|--|
| .01 | Maximum logical nozzle number for each side, | 1-4 (5-8 optional), |
| .02 | Dispenser geometry, single sided / double sided, | 1 = single (side A)
2 = double or single (side B) |
| .03 | General valve type,
(0 = Use default in template for all primary, secondary valves; see F08/F09)
1 = ASCO On/Off
2 = Skinner Proportional Not used
3 = ASCO Proportional | 1-3 |
| .04 | UPD re-orientation, side A,
(inverts selected orientation for) | 0 = Disabled
1 = side A
2 = side B
3 = side A+B |
| .05 | UPD mapping
0 = Disabled
1 = map all UPD to second UPD panel
2 = map 1 st UPD to UPD panel 2 and 2 nd on panel 3 ‘
(when a 4 UP Display is used in a 4/2 pump)
3 = map 1 st UPD to UPD panel 1 and 2 nd on panel 3
(when a 3 UP Display is used in a 4/2 pump) | |
| .06 | Display Type, | 0 = standard display (default)
1 = VISTA type display |
| .07 | Nozzle switch sense, | 0 = “normally closed” (default)
1 = “normally open”. |
| .08 | EMT mapping
0 = standard mapping EMT
1 = standard mapping on side A and product M1 to M4 is mapped as M4 to M1 on totalizer board side B
2 = standard mapping on side B and product M1 to M4 is mapped as M4 to M1 on totalizer board side A | |

3.8.39 F38 - Country Configuration:

Setting the Country Configuration number will write the default values specified for the specific Country.

Default values will always be written to F14, 16, 17, 19, 20, 21, 22, 23, 24, 25, 26 and 70.

Make sure that you always select the country configuration number first before setting a related function.

Any change to the country configuration will overwrite previous settings of the above Function registers!

Enter country number to be configured:

- | | |
|-----|--|
| .00 | country number
1 = Brazil
2 = Germany
3 = UK, Ireland
4 = Sweden
5 = EURO
6 = BeNeLux
7 = Poland
8 = Brazil Export
9 = Spain |
|-----|--|

- 10 = Italy
- 11 = Turkey

3.8.40 F39 – Error level assignment

.00 - .99

restricted for the vapour recovery error levels only (42, 43, 44, 45, 46, 47)

- 0 = LOG
- 1 = Termination, terminate filling
- 2 = SEMI Fatal, close current dispenser side
- 3 = Fully Fatal, close both dispenser sides

3.8.41 F40 – Manual VAP calibration without the Buerkert Handterminal

See manual VAP description

3.8.42 F41 – Backlight, Red/Green outputs, Spare In/Outputs assignment

- .01 side A backlight functionality
 - 0 = disabled
 - 1 = backlight on in all dispenser states except closed, off when in closed state
 - 2 = backlight turned OFF in maintenance mode.
 - 3 = backlight turned OFF in maintenance mode. Backlight output common for side A and B.
I e if any of sides A or B are open backlight will be turned on (not in maintenance mode).
- .02 side B backlight functionality
This function provides the same functionality on side B as 01
- .03 side A Red/Green functionality
 - 0 = disabled
 - 1 = Green lamp application, lamp OFF when nozzle replaced until cashed, otherwise ON
 - 2 = Red lamp application 1, Idle state = OFF, nozzle out = OFF, volume > suppressed volume = OFF, nozzle in = ON, filling cashed = OFF
 - 3 = Red lamp application 2, Idle state = OFF, nozzle out = OFF, volume > suppressed volume = ON, nozzle in = FLASHING, filling cashed = OFF
 - 4 = Video output
 - 5 = OPT Lamp control continuously ON (activated via DART command CD7)
 - 6 = OPT Lamp control blinking 0,5Hz (activated via DART command CD7)
 - 8 = Vapour Gate VRM status signal. To control OPT lamp or to be read by other system via junction box.
VRM OK = off,
Timer running = 0.25Hz (OFF 2 seconds, ON 2 seconds),
Timer elapsed = 0.5Hz (OFF 1 second, ON 1 second),
HW error detected = 1Hz (OFF 0.5 seconds, ON 0.5 seconds)
 - 9 = AdBlue door status. Blink if AdBlue door is not closed properly.
- .04 side B Red/Green functionality
This function provides the same functionality on side B as 03
- .05 Spare Out 1 functionality

- 0 = disabled
 - 1 = Vapour recovery pulse output side A (no pulses if vapour recovery is disabled in F10/F11)
 - 2 = Pulse output for side A (pulse output always enabled)
 - 5 = Speaker Relay Control
 - 8 = Oil barrel refill signal (Oilmix pump)
 - 9 = Vapour Gate Self Check Valve side A
- .06 Spare Out 2 functionality
- 0 = disabled
 - 1 = Vapour recovery pulse output side B (no pulses if vapour recovery is disabled in F10/F11)
 - 2 = Pulse output for side B (pulse output always enabled)
 - 6 = Clean Air VAP signal (if filling on VAP nozzle on any of the sides the output is activated)
 - 9 = Vapour Gate Self Check Valve side B
- .07 Spare Out 3 functionality
- 0 = disabled
 - 1 = Vapour recovery pulse output side A (no pulses if vapour recovery is disabled in F10/F11)
 - 2 = Pulse output for side A (pulse output always enabled)
 - 3 = CASH-button status
 - 7 = Nozzle out indication side A
 - 9 = Vapour Gate Self Check Valve side A
- .08 Spare Out 4 functionality
- 0 = disabled
 - 1 = Vapour recovery pulse output side B (no pulses if vapour recovery is disabled in F10/F11)
 - 2 = Pulse output for side B (pulse output always enabled)
 - 3 = CASH-button status
 - 7 = Nozzle out indication side B
 - 9 = Vapour Gate Self Check Valve side B
- .09 Spare In 1 functionality
- 0 = not assigned
 - 3 = Vapour Gate VR Meter Input side A (set automatically when configuring F26.04 = 3).
 - 4 = Maintenance key is enabled (connector J12 pin 1+2)
 - 5 = Local authorize input side A
 - 6 = Tank Level Low detection
 - 7 = UPS signal (Run on battery backup or not)
 - 8 = Oil barrel low signal (Oil mix pump)
 - 10 = Vapour Flow Switch input
- .10 Spare In 2 functionality
- 0 = not assigned
 - 3 = Vapour Gate VR Meter Input side B (set automatically when configuring F26.04 = 3).
 - 5 = Local authorize input side B
 - 6 = Tank Level Low detection
 - 9 = Oil barrel full signal (Oil mix pump)
 - 10 = Vapour Flow Switch input
- .11 Spare output for product ID on Expansion board (4 grades/nozzles per side) used for eg voice synthesizer.
- 0 = disabled
 - 1 = active low signal. Grade bit = 0 for selected nozzle.
 - 2 = active high signal. Grade bit = 1 for selected nozzle.
- .12 Spare in, Physical nozzle input 4 on side A
- 4 = Maintenance key is enabled

3.8.43 F42 – GHM rotation

- .01 GHM 1, exchange meter assignment
0 = disabled
1 = exchange
- .02 GHM 2, exchange meter assignment
0 = disabled
1 = exchange
- .03 GHM 3, exchange meter assignment
0 = disabled
1 = exchange
- .04 GHM 4, exchange meter assignment
0 = disabled
1 = exchange
- .05 GHM 5, exchange meter assignment, reserved
0 = disabled
1 = exchange
- .06 GHM 6, exchange meter assignment, reserved
0 = disabled
1 = exchange

3.8.44 F43 - Motor feedback

- .00 0 = Motor feedback disabled for all motors
1 = Motor feedback enabled for all motors. Reset via F43.01=0 in maintenance mode.
2 = Motor feedback enabled for all motors. Reset via Power cycle.
3 = Motor feedback enabled for all motors. Reset via maintenance mode entry (CRC-button or Remote Control).
4 = Motor feedback enabled for all motors. Reset via any of the above.
- .01 Error is indicated
Motor 1 = value 1
Motor 2 = value 2
Motor 3 = value 4
Motor 4 = value 8
For example :
If no motor has shut off -> F43.01 = 0
If motor 2 and 3 has shut off -> F43.01 = 6 (2+4)
Further fillings (which use the erroneous motor) are inhibited until "flag" is cleared in F43.01
For example :
If F43.01 = 3-> motors 1 and 2 has shut off.
If one write 1 in F43.01 only motor 1 is shut off.
If 0 (zero) is written in F43.01 then all motor errors are cleared.

3.8.45 F44 – Hydro Filter Configuration

Sub-function numbers are in the format: ` .MM' where MM = the meter number 01-12.

- .MM Meter mapped to inlet with Hydro Filter mounted 0-5,
where...
0 = No
1-5 = number of consecutive fillings allowed with filter clogged before closing pump.

F49.05	Side A, 30 lpm	F49.15	Side B, 30 lpm
F49.06	Side A, 35 lpm	F49.16	Side B, 35 lpm
F49.07	Side A, 40 lpm	F49.17	Side B, 40 lpm
F49.08	Side A, 45 lpm	F49.18	Side B, 45 lpm
F49.09	Side A, 50 lpm	F49.19	Side B, 50 lpm

3.8.51 F50 – ATC, Product Type Assignment

Sub-function numbers are in the format: ` .MM' where MM = the meter number 01-12.

.MM Product type mapped to a meter number.

Product type...

0 = Gasoline

1 = Diesel

2 – 8 Reserved for future fueltypes to be supported by ATC

9 = no product mapped

NOTE! Access to this parameter is not possible without W&M switch on TM board being in un-protected position.

3.8.52 F51 – ATC, Density Assignment

Sub-function numbers are in the format: ` .MM' where MM = the meter number 01-12.

.MM Density mapped to a meter number.

Allowed density range is determined by product type...

Product Type	Min Density	Max Density
Gasoline	600 g/dm ³	770 g/dm ³
Diesel	788 g/dm ³	838 g/dm ³

NOTE! Access to this parameter is not possible without W&M switch on TM board being in un-protected position.

3.8.53 F52 – ATC, Probe # Assignment

Sub-function numbers are in the format: ` .MM' where MM = the meter number 01-12.

.MM Temperature Probe # mapped to a meter number.

Probe numbers 0 – 10 can be assigned. 0 = no probe assigned.

NOTE! Access to this parameter is not possible without W&M switch on TM board being in un-protected position.

3.8.54 F53 – ATC, Temperature Offset Adjustment

Sub-function numbers are in the format: ` .MM' where MM = the meter number 01-12.

.MM A temperature offset of -7 up to +7 can be set (default 0) representing -7°C to +7°C.

Only possible to set negative values using the UP and DOWN keys since no “minus” (-) key on the remote control.

The temperature offset can be used to adjust an offset if detected during calibration. Normally this is not required.

NOTE! Access to this parameter is not possible without W&M switch on TM board being in un-protected position.

3.8.55 F54 – Miscellaneous Configuration Part 2

- .00 CAN bus 1 = enabled, 2 = disabled (default)
- .01 iGem user interface via iX.
 - 0 = No application (default)
 - 1 = iGem user interface enabled.
- .02 Display LED application
 - 1 = Product select indication
 - 2 = Vapour Flow switch indication (default)
 - 3 = Bürkert Status indication
 - 4 = Aral Preset indication

3.8.56 F70 - Access level

- .00
 - 1 = access table 1(Brazil)
 - 2 = access table 2(Germany)
 - 3 = access table 3(UK)
 - 4 = access table 4(Sweden)
 - 5 = access table 5(Netherlands)
 - 6 = access table 6(Italy)
 - 7 = access table 7(Brazil international)

3.8.57 F96 - Upload Flash Memory Programming

This function requires the service terminal, NOT the remote control.

This function has no sub-functions. Press ENTER to transmit the FLASH program data. The service terminal program requests a filename to upload the data to. Select the file to begin the program upload. When the FLASH program upload finishes, the IGEN goes back to function entry mode where you may access other functions.

3.8.58 F98 - Download Flash Memory Programming

See chapter SW download, Function 98 Download at the end of this document

3.8.59 F99 – Not used

3.9 Statistics List

The software controls access to statistics and sub-statistics. It contains an access level table that determines what functions each user has access to. Access levels are as follows:

- Read and Write
- Read only
- No access

To **enter the statistics** viewing mode press either the **UP or DOWN arrow when the unit price is displaying "F - - "**. When you enter the statistics viewing mode, the unit price display window shows "S - - ", the money display window shows the current transaction count for side B, and the volume display window shows the current transaction count for side A. To view specific statistics, enter any statistic number using the number keys and press ENTER. The corresponding number shows in the money display window.

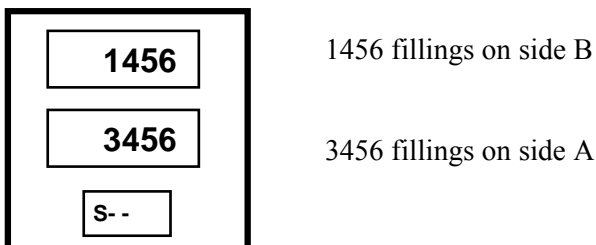

The following is a comprehensive list of defined statistics:

Describe how to reset totals!

3.9.1 S01 - Side A Totals by Logical Nozzle

Sub-statistic numbers in the format '.TN'

T = totals type:

1 = Volume

2 = Total Money

3 = Credit

4 = Cash

5 = Serial Filling Mode Filling Count

6 = Stand Alone Mode Filling Count

7 = Gross (un-compensated) Volume

N = logical nozzle number 0-8 (0 = None Assigned)

The least significant six (6) digits of the data value appear on the volume display. Higher order non-zero digits of the data value, if present, appear on the money display. Leading zeros appear as blanks.

To reset totals:

- 1) Press #. Display indicates "CLEAR totALS"
- 2) Press "ENTER". Display indicates "PASS"
- 3) ENTER PASSWORD "XY" and press ENTER (Enter Verification Code Password)

3.9.2 S02 - Side B Totals by Logical Nozzle

This statistic provides the same functionality on side B as S01

3.9.3 S03 - Side A Error/Event Counter Totals

The money display is in the form of dashes and sub-statistic displays on the unit price display in the range 1-99 representing the set of error/events detectable by the program. The allowed range for the counter value is 0-255.

See Error/Events Types list.

3.9.4 S04 - Side B Error/Event Counter Totals

This statistic provides the same functionality on side B as S03

3.9.5 S05 - Side A Meter Volume Totals

Sub-statistic numbers in the format '.MM' where 'MM' = meter number

MM = 1-12: Meter Volume

MM = 21 – 32: Gross (un-compensated) Volume for meters 1-12 (21→ meter 1 , 32 meter→ 12)

The least significant six (6) digits of the data value appear on the volume display. Higher order non-zero digits of the data value, if present, appear on the Money display. Leading zeros appear as blanks.

To set totals:

1. Press #.
2. Enter desired start value.
3. Press ENTER twice.

3.9.6 S06 - Side B Meter Volume Totals

This statistic provides the same functionality on side B as S05

3.9.7 S07- S10: RESERVED

3.9.8 S11 - Side A Totalizers by Logical Nozzle

Sub-statistic numbers in the format '.TN':

T = Totals type

1 = Volume

2 = Total Money

3 = Credit

4 = Cash

5 = Serial Filling Mode Filling Count

6 = Stand Alone Mode Filling Count

7 = Gross (un-compensated) Volume

N = logical nozzle number 0-8 where 0 = None Assigned

The least significant six (6) digits of the data value appear on the volume display. Higher order non-zero digits of the data value, if present, appear on the Money display. Leading zeros appear as blanks.

3.9.9 S12 - Side B Totalizers by Logical Nozzle

This statistic provides the same functionality on side B as S11

3.9.10 S13 - Side A Error/Event Counter Totalizers

The money display shows dashes and the volume display shows the statistic data. The unit price display shows the statistic and sub-statistic numbers in the format `14.XX' where `XX' is in the range 0-99 representing the set of error/events detectable by the program. The allowed range for the counter value is 0-999.

See Error/events types list.

3.9.11 S14 - Side B Error/Event Counter Totalizers

This statistic provides the same functionality on side B as S13

3.9.12 S15 - Side A Meter Volume Totalizers

Sub-statistic numbers in the format '.MM' where 'MM' = meter number

MM = 1-12: Meter Volume

MM = 21 – 32: Gross (un-compensated) Volume for meters 1-12 (21→ meter 1 , 32 meter→ 12)

The least significant six (6) digits of the data value appear on the volume display. The higher order non-zero digits of the data value, if present, appear on the Money display. Leading zeros appear as blanks.

3.9.13 S16 - Side B Meter Volume Totalizers

This statistic provides the same functionality on side B as S15

3.9.14 S17 - S20: RESERVED

3.9.15 S21 - Side A Error/Event Log

Sub-statistic numbers in the format '.XX' with the range 01-50 representing the set of error/events records maintained by the program, with the record in sub-statistic 01 being the most recent. Display error log data by using the two (2) data `pages' shown in an alternating sequence at a 1 second per page.

See Error Codes for a list of error codes.

Page 1 has the following format:

Page 1 has the event time on the Money display in the format HH.MM, not used. The volume display has data in the format CC.DD.NN where CC = the error/event code in the range 1-99, DD = the device number associated with the error/event and NN = the logical nozzle 0-8 selected at detection of the event (0 = none selected).

0000
580101
21.01

. HH.MM, (not used)

CC.DD.NN,
(i.e. **58**=Com. Failure with WIP, **01**=WIP no. 1, **01**=LogNoz 1)

where:

HH = hour, not used

MM = minute, not used

CC = error code

DD = device number

NN = logical nozzle number

Page 2 has the following format:

Page 2 shows the event date on the Money display in the format MM.DD.YY and the filling count for the side on the volume display.

0000
27456
21.01

MM.DD.YY, (not used)

C, filling count no.
(i.e. the error occurred on filling count number 27456)

where:

MM = month, not used

DD = day, not used

YY = year, not used

C = filling count

3.9.16 S22 - Side B Error/Event Log

This statistic provides the same functionality on side B as S14

3.9.17 S23 - Side A Transaction History Log

This statistic is showing the last 10 fillings.

Sub-statistic numbers in the format '.XX' with the range 01-10 corresponding to the last 10 fillings. The record displayed in sub-statistic 01 is the most recent and 10 is the oldest. View statistic data on the two (2) data 'pages' shown in an alternating sequence at a frequency of 1 second per page.

Page 1 shows: **amount** on the money display and the **volume** on the volume display.

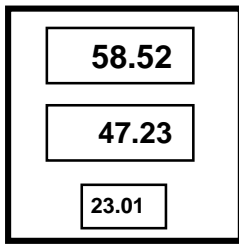

Amount (i.e. 58,52 €)

Volume (i.e. 47,23 litre)

Page 2 shows the **unit price** on the money display and the **volume** on the volume display.

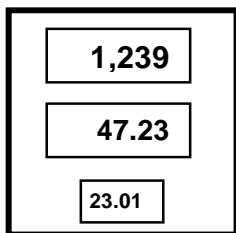

Unit price (i.e. 1,239 €)

Volume (i.e. 47,23 litre)

3.9.18 S24 - Side B Transaction History Log

This statistic provides the same functionality on side B as S23

3.9.19 S25 - Total Number of Power Cycles

Sub-statistic numbers are displayed in the format '0X' where X = the selected configuration parameter defined as follows:

- 00. Number of Power Cycles
- 01. Number of Software Resets
- 02. Number of Cold Start Power Cycles

3.9.20 S26 - Reset history

This statistic provides information for a software engineer to aid in troubleshooting.

Shows the date, time, reason, and return location for the last 50 resets. Sub-statistic numbers in the format '.XX' with the range 01-50 representing the set of reset event records maintained by the program. The record displayed in sub-statistic 01 is the most recent and 50 is the oldest.

View statistic data on the two (2) data 'pages' shown in an alternating sequence at a frequency of 1 second per page. Page 1 shows the event time on the Money display in the format HH.MM. The volume display has data in the format TT.FFFF where TT = the trap id, FFFF = the value of the trap flag register, (TFR) at detection of the reset.

Page 2 shows the event date on the Money display in the format MM.DD.YY and the return address as SS.OOOO where SS is the hex code segment, and OOOO is the hex offset into the code segment. The return address can be used to determine the PC contents when the trap occurred. This can be especially helpful for unexpected traps such as illegal instructions, odd word fetches, etc.

NOTE! Code 80.xxxx in volume display means that watchdog reset has occurred.

3.9.21 S27 – Statistic of the WIPs

The information below is requested from the serial WIP to be indicated on the iGEM display

M = Meter number, meter 1 - 12

0M, WIP serial number

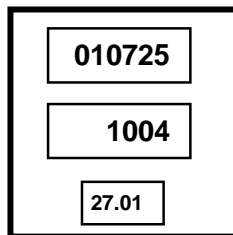

Batch number: 010725 (YYMMDD, i.e. 25. July 2001)

Number 1004

Meter 01

2M, totalizer of the WIPs, 8 digits (least significant 6 digits of the data appear on the volume, higher order 2 digits to the right of the money display)

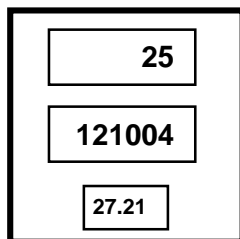

totalizer: (i.e. 251210,04 litre)

Meter 1

4M, previous WIP totalizer, (Totalizer of replaced WIP) (least significant 6 digits of the data appear on the volume, higher order 2 digits to the right of the money display), and counter of replaced WIPs, 3 digits to the left of the money display

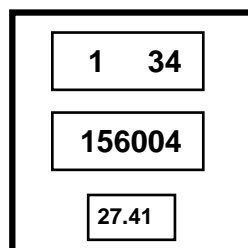

Counter of replacements (i.e. 1)

totalizer: (i.e. 341560,04 litre)

Meter 1

6M, pulse errors of the WIP

pulse errors: (i.e. 169)

Meter 1

8M, back pulses of the WIP

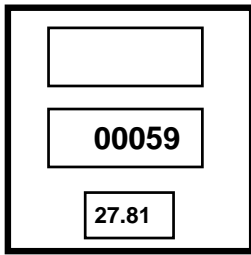

backpulses: (i.e. 59)

Meter 1

3.9.22 S28 - Side A Vapour Recovery Filling History Log

Logical nozzle number of the ten (10) last Vapour Recovery Fillings are logged here. Only fillings of > 8,3 liters are logged. This statistic is useful when troubleshooting problems with VR Monitoring.

3.9.23 S29 - Side B Vapour Recovery Filling History Log

Same as S28 but for side B.

3.9.24 S30 - Reserved

3.9.25 S31 - Side A Vapour Recovery Log

Sub-statistic numbers in the format '.XX' with the range 00-19 where lowest value represent latest filling. This log is used by Vapour Gate system and Vapour Flow Switch system.

The full log is used when Vapour Gate system is activated.

Part of the log (pages 1, 3 and 4) is used when Vapour Flow Switch is activated, see Note below.

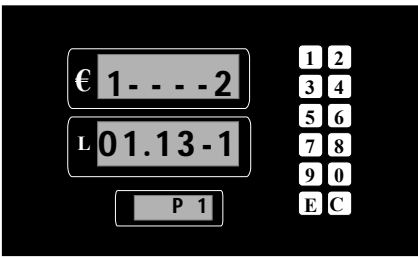
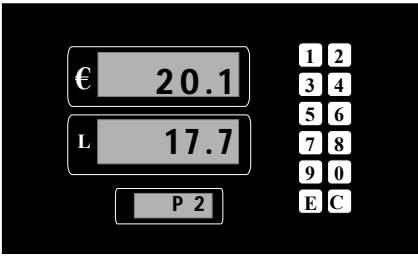
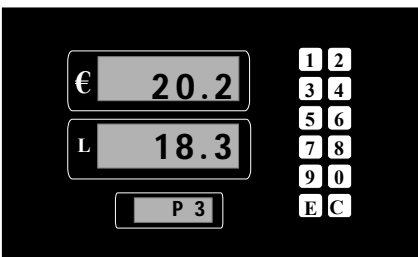
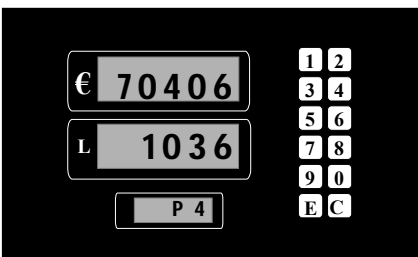
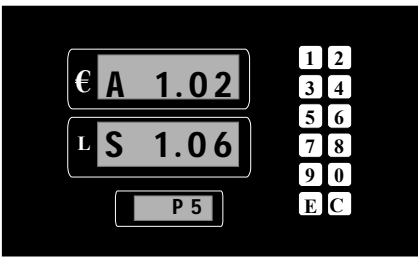
Layout of VRM history log	
	<p>Page 1</p> <p>Amount display: Status¹ and consecutive error filling. (Status 1 and 2:nd consecutive error filling)</p> <p>Volume display: A/L and nozzle. (A/L of 113% on nozzle 1)</p> <p>Unit price display: "P 1" altered with statistic and sub statistic ("30.xx").</p> <p>Note: For Vapour Flow Switch application the A/L (01.13) are dashed ("----").</p>
	<p>Page 2</p> <p>Amount display: Vapour volume of monitoring part.</p> <p>Volume display: Fuel volume of monitoring part.</p> <p>Unit price display: "P 2" altered with statistic and sub statistic ("30.xx").</p> <p>Note: This page is not used by Vapour Flow Switch.</p>
	<p>Page 3</p> <p>Amount display: Vapour volume of complete transaction.</p> <p>Volume display: Fuel volume of complete transaction.</p> <p>Unit price display: "P 3" altered with statistic and sub statistic ("30.xx").</p> <p>Note: For Vapour Flow Switch is Amount display dashes (- - - - -).</p> <p>Note: There can be a difference between filled volume in display and fuel volume in this log when ATC is activated.</p>
	<p>Page 4</p> <p>Amount display: Date of filling</p> <p>Volume display: Time of filling</p> <p>Unit price display: "P 4" altered with statistic and sub statistic ("30.xx").</p>
	<p>Page 5</p> <p>Amount display: Reference A/L. (Reference A/L of 102%)</p> <p>Volume display: A/L for self check (if done)</p> <p>Unit price display: "P 5" altered with statistic and sub statistic ("30.xx").</p> <p>Note: This page is not used by Vapour Flow Switch.</p>

¹ See separate Vapour Gate or Vapour Flow Switch section of this document.

3.9.26 S32 - Side B Vapour Recovery Log

Same as S31 but for side B.

3.9.27 S33 - Side A Vapour Recovery Log, Error period

Sub-statistic numbers in the format '.XX' with the range 00-29.

Data is presented in same format as for S31 (see previous page).

This log is used by Vapour Gate system and Vapour Flow Switch system.

This log is empty until the VRM timer has triggered to start. When this occurs, the 10 consecutive erroneous fillings that triggered the timer as well as the 10 preceding fillings are available. The log will keep updating with the 10 subsequent fillings then freeze.

- .00 - .09 Fillings that did not trigger the timer (not 10 consecutive erroneous fillings).
- .10 - .19 The 10 consecutive fillings where .19 was the 10:th that triggered the VRM timer to start.
- .20 - .29 The 10 subsequent fillings following after the timer started (will be added as they occur)

3.9.28 S34 - Side B Vapour Recovery Log, Error period

Same as S33 but for side B.

3.10 Weights and Measures Mode

By pressing CLEAR on the remote control when not in maintenance mode, the W&M audit trail is entered. In this mode one can trace changes of some critical parameters.

- View Blend Ratio Change Event Logs (if configured to blend)
- View Volume Metering Unit Change Event Logs
- View ATC Configuration Change Event Logs (if configured to have ATC)
- View Vapour Gate VR Monitoring Configuration Change Event Logs
- View volume totals/totalizers per side
(meter or nozzle totals depend on F21.05 and totals/totalizers depend on F21.08).

3.11 Readout of Totalizers/Totals in Weights and Measures Mode

If you enter the maintenance mode through a weights and measures entry (CLEAR button on Remote Control), a special weights and measures mode version of the maintenance mode automatically starts. This special mode is designed to make it as easy as possible to display the Totals / Totalizers. If you don't press any other button within 20 seconds, the next values are automatically displayed. Pressing NEXT displays the next totals/totalizer value. Pressing CLEAR exits the weight and measure mode. Weight and measure mode is exited when all totals/ totalizer are indicated.

Access the Totalizers/Totals readout by pressing the CLEAR button.
The display will show:

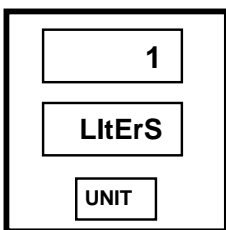

Indication, that the values are shown in Litres

Automatically after 20 sec. or when you press the NEXT button the totalizers/totals value appear:

The least significant six (6) digits of the data value appear on the volume display. Higher order non-zero digits of the data value, if present, appear on the money display. Leading zeros appear as blanks.

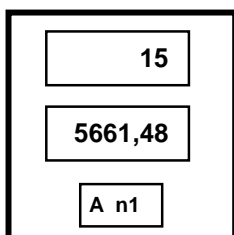

i.e. 155661,48 litres

Side A nozzle 1

The least significant six (6) digits of the data value appear on the volume display. Higher order non-zero digits of the data value, if present, appear on the money display. Leading zeros appear as blanks.
To reset totals:

4 Error Codes

4.1 Error/Event Classification

Depending on how serious an error or event is, it may be handled differently. Errors/Events shall be classified as specified in the table below:

Error Type	Classification	Description
LOG	A	Error/event is only logged.
TERMINATION	B	Error/event is logged as specified above and filling is terminated.
SEMI-FATAL	C	Error/event is logged as specified above, filling is terminated and current dispenser side is closed.
FULLY-FATAL	D	Error/event is logged as specified above, filling is terminated and both dispenser sides are closed.
CATASTROPHIC	E	Error/event is logged as specified above, filling is terminated and both dispenser sides are closed, power cycle must be done
INDICATION	F	Error/event is not logged, but certain message on display gives information about error
DISABLED	G	Error is not logged, no action

4.2 Error/Event Types

The following table specifies how error/events are classified. The template shall determine the classification of each error/event. The error/event numbers in the first column of the table may be changed during implementation and are provided in this table only as an aid in comprehending the information.

No.	Error/Event	Description	Classification
1	Flash Program Memory Failure	CRC on Flash Program Area is incorrect	E
2	Flash Template Memory Failure	CRC on Flash Template Area is incorrect	E
3	RAM Memory Failure	Read/Write/read test has failed	E
4	Power Failure	Power drops below 4.5VDC.	Causes Reset
5	Error Log Database Failure	CRC on Error Log Database is incorrect	D + Clear DB
6	Configuration Database Failure	CRC on Configuration Database is incorrect	D + Clear DB
7	Unit Price Database Failure	CRC on Unit Price Database is incorrect	D + Clear DB
8	Statistics Database Failure	CRC on Statistics Database is incorrect	D + Clear DB
9	Event Log Database Failure	CRC on Event Log Database is incorrect	D + Clear DB
10	Totals Database Failure	CRC on Totals Database is incorrect	D + Clear DB
11	Totalizers Database Failure	CRC on Totalizers Database is incorrect	D + Clear DB
12	EM Totalizers Database Failure	CRC on EM Totalizers Database is incorrect	D + Clear DB
13	Identity Prom Data Error	CRC on Identity Prom data is incorrect . <i>Logged on reset / power-on</i>	A
14	Manual VR calibration data error	CRC on VR calibration data is incorrect	A + Clear DB
15	N/A	N/A	N/A
16	Overflow Limit Reached	Limit for suppressed overflow has been reached	B
17	Hose test volume	Hose test volume out of tolerance	B
18	Hose test volume	Hose test volume out of tolerance (on three consecutive fillings)	C
19	N/A	N/A	N/A
20	Display Read back Error	Configured maximum number of display read back errors has been reached (-> F.17.02)	B
21	ATC: Communication failure	Communication lost with TM board or CAN/TTL converter.	B
22	ATC: Probe Shortened	One of the PT100 probes are shortened.	B
23	ATC: Probe open	One of the PT100 probes is open/not connected.	B
24	ATC: Invalid fuel type	Fuel Type doesn't match the density range.	C

No.	Error/Event	Description	Classification
25	Filling Start with Zero Unit Price	Attempted start of filling with Zero (0) Unit Price	B
26	Filling Start with No Unit Price Downloaded	Attempted start of filling with no Unit Prices downloaded from POS.	B
27	Filling Start after Unit Price Change	Attempted start of filling before Unit Price change timeout (-> F23.04)	B
28	Filling start without Preset Entry	Nozzle Lifted without Preset Entry though required (-> F24.01 = 1)	B
29	Sale start price SAT not equal MASTER	Attempted start of filling and the unit price is not equal at SAT and MASTER	B
30	POS Communication Lost	No poll from POS for time exceeding configured maximum offline time -> F23.02	C
31	POS task buffers full	Rx and/or Tx buffers in DART task is full	A
32	POS CRC error	CRC of received POS message is incorrect	A
33	N/A	N/A	N/A
34	STOP button pushed	Filling terminated due to STOP button press	B
35	Blending out of tolerance	Blend Error exceeds configured max Value (%) (-> F.18)	B
36	No flow on one meter at high speed/blender pump	Volume ratio between the assigned meters is < 0,5%	B
37	VAP Monitor 10 fillings bad	10 fillings in row with vapour recovery flowrate out of tolerance	A
38	VAP Monitor 72h elapsed	72 hours elapsed after error code 37	A
39	VAP Monitor internal error	Internal VAP Monitor System (Vaporix) error or not connected	A
40	VAP Monitor Reset	VAP Monitor System (Vaporix) has been reset	A
41	Motor feedback	Errors from motor	B
42	Vap not calibrated	VAP system not calibrated yet	A
43	Vap valve current low	Valve current is low (e.g. no valve connected)	A
44	Vap valve current high	Valve current is high (e.g. short circuit on valve output)	A
45	Vap contactor error	No contactor detected	A
46	Vap external error	Error detected via external signal input	A
47	Vap electric error	Vap hardware error	A
48	VR consecutive filling	For Vapour Flow Switch and Bürkert indication, maximum consecutive erroneous fillings reached.	A
49	Illegal WIP incrementation	Possible fraud attempt. Contact Wayne.	E

No.	Error/Event	Description	Classification
50	Error on WIP in use	Errors from WIP used in Transaction (-> F17.00)	B
51	Error on idle WIP	Errors from WIP not used in Transaction (-> F17.01)	A
52	No response from WIP in use	No response from WIP used in Transaction	A
53	N/A	N/A	N/A
54	Back pulses from idle WIP	Back pulses from WIP not used in Transaction (-> F16.03)	B
55	N/A	N/A	N/A
56	Forward Flow on idle WIP	Forward flow on WIP Not used in Transaction (indication of leakage) (-> F19.14)	B
57	N/A	N/A	N/A
58	Comm failure with WIP in use	WIP used in transaction didn't respond on re-transmission.	B
59	Comm failure with WIP in idle	WIP didn't respond to heart beat message	A
60-61	N/A	N/A	N/A
62	WIP serial number mismatch	WIP is exchanged.	C
63-65	N/A	N/A	N/A
66	LPG calibration factor mismatch	LPG WIPs needs to be calibrated. <i>To calibrate</i> 1) <i>enter maintenance mode and set parameter F16.05=1.</i> 2) <i>Remove calibration magnet from meter to be calibrated</i> 3) <i>exit and save</i> 4) <i>return calibration magnet.</i>	C
67-69	N/A	N/A	N/A
70	No Flow Timeout	Filling was started but no fuel has been dispensed for configurable time (-> F17.03)	B
71	Consecutive number of no flow	Configured number of maximum consecutive No Flow events has been reached (-> F17.04)	B
72	Flow Lost Timeout	Flow was lost for configured maximum time (-> F17.03)	B
73	Consecutive number of lost flow	Configured number of maximum consecutive Flow Lost events has been reached (-> F17.05)	B
74	Unfinished filling	Filling ended before preset or prepay limit was reached	B
75	Consecutive number of unfinished fillings	Configured number of unfinished fillings has been reached (-> F17.06)	B

No.	Error/Event	Description	Classification
76	Hydro Filter Clogged	Consecutive number of fillings with Hydro Filter Clogged (F44)	C
77	Battery level Low	Battery for non-volatile RAM is < 2,5 V	A
78	LPG Excess Flowrate	Flowrate > 80 lpm on LPG nozzle	B
79	N/A	N/A	N/A
80	RTOS mail buffer exhausted	Mail buffer of RTOS is exhausted	B
81	F03 not programmed	F03 is not programmed and pump running in standalone mode	F
82	F04 not programmed	F04 is not programmed and pump running in standalone mode	F
83	F05 not programmed	F05 is not programmed and pump running in serial mode	F
84	F06 not programmed	F06 is not programmed and pump running in serial mode	F
85	F37 not programmed	F37 (pump model type) is not programmed	F
86	F38 not programmed	F38 (country code) is not programmed	F
87	ATC: Configuration error	Not same density or product type on meters sharing same probe.	F
88	UPS Error	Power failure, we are running on Battery backup.	E
89	Tank Level Low	Tank level low is detected.	C
89-99	N/A	N/A	N/A

5 Miscellaneous IGEM Functions

5.1 Performing a Cold Start

5.1.1 Alternative 1: Perform a cold start to reset statistical and functional values.

1. Turn off power to the pump computer board.
2. On the IGEM pump computer board, short across the cold start jumper S15.
3. While keeping it shorted, apply power to the pump computer board, keeping it shorted until the word COLd displays in the volume display.
4. Remove the short across. The cold start procedure is now complete, the word Cold disappears from the display.

5.1.2 Alternative 2: Perform a Soft cold start to reset all statistical and functional values by Function Register F00.

5.2 IGEM Data Dump

To help diagnose problems at a site, the IGEM pump computer can dump function programming and statistical data through the Service Terminal Program to a file on the laptop. This file can then be sent to Wayne for analysis.

The IGEM data dump is accessed by a special button on the Service Terminal Program called "IGEM DATA DUMP". This button is active only if maintenance mode has been entered and the current state shown in the unit price displays is "F--". The display on the Service Terminal program will show "ENTER FUNCTION". If the maintenance mode is in this state, then selecting the IGEM DATA DUMP button causes the Service Terminal Program to request a filename to which to upload the IGEM data. When the file is selected, the data dump is started.

Upon completion of the data dump, the IGEM will go back to function entry mode where other functions may be accessed.

5.3 Pumping unit flow lost check to avoid dry operation when two meters are assigned to one nozzle

On pumps/dispensers where more than one meter (i.e. 130l/min or blenders) is used, the flow through the meters is checked. At start of filling, after 5 litres are dispensed, the flow ratio is checked. If the ratio between the meters is smaller than 0,5%, the filling will be terminated and error code 36 logged. Example, Diesel pump 130 l/min:

1. No flow from 1st meter, flow from 2nd meter => iGEM will stop filling after 5 litres.

This functionality is disabled when W&M mode is selected by function F01.

5.4 Calibration when two meters are assigned to one nozzle

If a calibration of the GHM is performed and more than one meter is assigned to one nozzle, the valve of the meter which is not being calibrated is closed automatically due to the open flap of the WIP pulser.

After calibration the flow lost check functionality is disabled for 3 fillings.

5.5 Pump Motor Feedback

Pumps in Europe (e.g. Global Star or Global Century) which are build with the ELNOR motor have a build in over load protection.

. The overload protection (thermal switch) doesn't have RESET on the motor. Instead iGEM detects if the motor protection has turned off the motor. If so, filling will be terminated and error logged. New filling on that can't be started until error has been reset.

The motor protection error (Error code 41) can be reset in different, see function F43.

That means, that in all pumps where this functionality is not requested (e.g. dispensers, LPG dispensers) or not wanted, the motor feedback parameter has to be disabled manually by the remote control.

From iGEM Software release (7.19) the motor feedback functionality will be switched on automatically for all applications after coldstart.

5.6 Nozzle out identification at power ON

An active nozzle switch (nozzle out) or defect/not connected nozzle switch will be recognised at the pump display. This identification disappears automatically when nozzle switch is recognised as inactive.

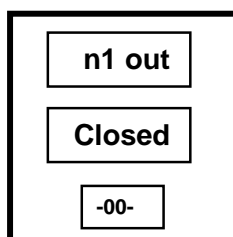

f.e. N1 out

5.7 40/90 Models

When running 40/90 pump without flowselection (e.g. 40 on one side and 90 on the other), configure as follow:

90 (no truck/car button): set High (F10/11.61) and Low (F10/11.71) buttons to 0 (zero).

40 (no truck/car button): don't change anything.

5.8 Vapour Gate VR Monitoring

This section contains basic information about the Vapour Gate VR Monitoring functionality. For more information, see the Vapour Gate Maintenance Manual.

5.8.1 Activation

To activate Vapour Gate first make sure that the Real Time Clock (RTC) is set correct in F02 then set F26.04 = 3, F41.07 = 9 and F41.08 = 9.

5.8.2 Error Indication

-	UPD displaying on dash indicates that Vapour Gate has detected 10 consecutive fillings with A/L out of limit and that pump will shut down in less than 72 hours .
--	Two dashes in UPD indicate same as above but less than 48 hours less until pump is shut down.
---	Three dashes in UPD indicate same as above but less than 24 hours less until pump is shut down.
OFF1	OFF1 indicate that the timer has elapsed and that pump is shut down for further use until problem is solved and error is reset.
OFF2	OFF2 is displayed when internal Vapour Gate error is detected.

On errors, check statistic registers S31 to S34 as well as S21 and S22.

5.8.3 Status Value in VRM log

Bit #	Problem	Description
0 (1)	A/L out of limit.	A/L for a filling is out of limits, less then 85% or greater then 115%. Counts as an erroneous filling.
1 (2)	Illegal meter signal (low frequency)	Possibly VR is blocked after vacuum pump (pressure side). Can also be bad sensor or incorrectly mounted sensor. System recovers automatically 20 seconds after error disappear. Counts as an erroneous filling.
2 (4)	<i>Reserved</i>	<i>Not used at the moment.</i>
3 (8)	10 consecutive errors, timer started.	There have been 10 consecutive erroneous fillings in row and the timer is started.
4 (16)	Illegal meter signal (high frequency)	Has deactivated meter signal input to iGEM and is not counting pulses at the moment. System recovers automatically 5 minutes after error disappear after 1:st occurrence and 30 minutes after subsequent occurrences. Also reset after power cycle.
5 (32)	Dirt in nozzle.	It is dirt in the nozzle. Counts as an erroneous filling. It also has a separate error counter per nozzle.

Example:

- Status value = 0: OK VRM filling
- Status value = 1: VRM filling out of limit
- Status value = 9: A/L out of limit and timer is started.
- Status value = 8: Timer started but last filling OK.

5.8.4 Remote Status Indication

Vapour Gate VR Monitoring does not support interface to so called Vaporix Master. To facilitate VRM related information remotely from the pump one can configure iGEM to beep 5 times in row (F15.04) on each nozzle return when timer has started. This feature require pump to be fitted with annunciator.

Additionally, one can configure iGEM to indicate Vapour Gate status (frequency) on red/green outputs of iGEM CPU board. If pump is equipped with OPT (red/green) lamp the status can be seen by operator inside station. If pump is equipped with junction box and suitable cabling to the red/green outputs, the signal can be interpreted by some other device/system.

If pump is running DART, the VRM status is reported to POS as alarm codes.

5.9 Vapour Flow Switch VR Monitoring

This section contains basic information about the Vapour Flow Switch VR Monitoring functionality.

5.9.1 Activation

To activate Vapour Flow Switch first make sure that the Real Time Clock (RTC) is set correct in F02 then set F26.04 = 5.

5.9.2 Error Indication

Error is indicated by a LED on the display board.

Red LED for 1 second after filling	Performed filling was erroneous.
Red LED constantly	There have been F47/F48.05 consecutive fillings with errors. VR system is not working correctly.
Green LED for 1 second after filling	Performed filling has no errors. This is lit even if red LED is lit constantly to indicate a filling without error.

On error, check statistic registers S31 to S34 as well as S21 and S22.

5.9.3 Status Value in VRM log

Bit #	Problem	Description
0 (1)	No vapour flow during filling	Possibly VR is blocked. Can also be bad sensor or incorrectly mounted sensor. Counts as an erroneous filling.
1 (2)	Vapour flow between filling	Possibly vapour leak. Can also be bad sensor or incorrectly mounted sensor. Counts as an erroneous filling.
2 (4)	X consecutive error in row	There have been X (F47/f48.05) consecutive erroneous fillings in row and red LED is lit constantly.

Example:

Status value = 0: OK VRM filling

Status value = 1: No vapour flow during filling.

Status value = 4: Max consecutive error occurred, but last filling OK.

5.10 ATC

To be able to set ATC parameters (F50 – F53) the security switch on the ATC board must be in unprotected position. iGem knows that the switch is in unprotected position 2-5 seconds after it has been changed.

The switch must be in protected position when leaving maintenance mode, or else an error is flashed “ATC CLOSED”. If this happens, set the security switch in protected position and reset iGem.

6 Software Download

6.1 General

The iGEM program, the so called BIN-file (iGEMxxxx.BIN) can be loaded by either a PC or a iGEM Master calculator via the serial interface (sitecontroller interface).

For the program loading, the pump computer's load sequence has to be activated by authorised service personnel (see below).

The Software can be loaded by 2 alternatives:

1. **Bootstrapp**

Bootstrapp mode has to be executed when

- the W&M software version has been changed or
- on boards where no pump software has been loaded to before or
- when while downloading the transmission has been interrupted

In case of the events above the PRG LOAD switch on the iGEM has to be switched on. Make sure that you always fulfil the local Weight and Measure demands.

2. **Function 98**

This mode can be executed only with iGEM software loaded to the board.

It is possible on RS485 (2 wire DART) or RS422 (4-wire LJCL) interface.

When program has been downloaded, a coldstart shall be performed.

To setup a specific pump model the Function F37 has to be assigned. This will load the default pump configuration.

To setup specific country parameters Function F38 has to be assigned to a defined country code.

Functions parameters modified by country and model selection should be programmed after F37 and F38 has been configured.

Beginning from iGEM software version 7.15 and PC Serviceterminal version 2.0 (SERVTERM2.0) the W&M software version is checked at beginning of the download sequence. If the W&M part of the software to be downloaded is different to the existing W&M software part on the iGEM board, the download process is interrupted and "W&M different" is displayed in the PC screen respectively "E-diff" on the iGEM Master's display.

Switch PRG LOAD switch on the iGEM board into ON position before retry. Make sure that you always full fill the local W&M demands if the switch is covered by a seal. Since breaking the seal on the switch is not allowed in Germany a new preapproved board has to be installed.

6.2 Differences Between iGEM Boards

6.2.1 Straps & Buttons

On 2:nd generation iGEM boards the straps for boot, reset and coldstart (S13, S14, S15) are replaced with pushbuttons .

Also communication straps S16, S17, S18, S19 and S20 are replaced with only one strap each for RS422, USCL, RS485 etc. A 9 pin "PC to PC" cable can be used (D-SUB connector) for download.

6.2.2 PROGRAM MEMORY

The first generation iGEM boards only had 512KB Program memory. Only program versions up to V7.xx can be loaded to these boards.

List of boards with only 512KB program memory:

168857	iGEM EPC EU Low cost
168863	iGEM EPC EU Low cost w US-ISB
168861	iGEM EPC US
168865	iGEM EPC US w EU-ISB
173926	iGEM EPC US w DART
168862	iGEM EPC EU Full
168864	iGEM EPC EU Full w EU-ISB

The second generation iGEM boards has 1MB of program memory and can have program version higher than 7.xx loaded (*NOTE! servTerm 2.09 is required*).

List of boards with 1MB program memory:

WM001908-0001	iGEM EPC IEC FULL
WM001908-0002	iGEM EPC IEC LOW COST
WM001908-0003	iGEM EPC US
WM001908-0004	iGEM EPC GLOBAL FULL
WM001908-0005	iGEM EPC IEC FULL w. CAN

6.3 Download on 1:st Generation iGEM Board

6.3.1 Bootstrapp Download PC (Notebook) to iGEM Board (pump)

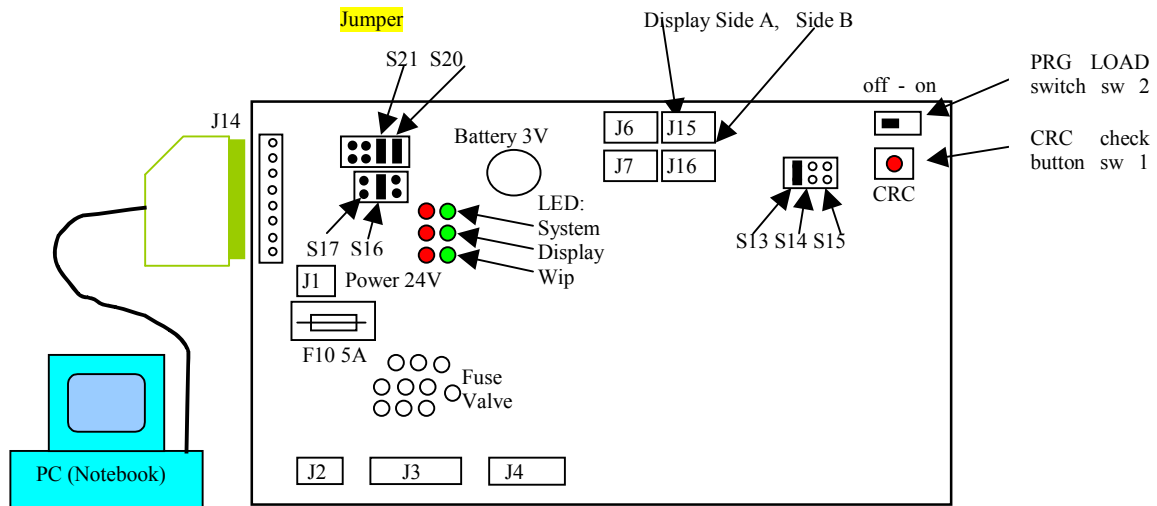

<ol style="list-style-type: none"> 1. Turn off the power to the iGEM in pump. 2. Connect PC and iGEM via download cable, (PC com port to J14 on the iGEM board) 3. Switch on PC 4. Check Jumper on the iGEM (picture). Set Jumper S21 (5 Volt to download box), Jumper S20, S16 and Jumper S13 (BOOT), if required S15 COLDSTART. 5. Switch on the iGEM 6. Start ServTerm.exe software at PC. Select "Boot" by BOOT button. "Entering GEM Boot Strap" appears. 7. Confirm "Entering GEM Boot Strap". 8. Select new iGEM.BIN file. 	<ol style="list-style-type: none"> 9. The file is now downloaded to the iGEM board, while each downloaded block is shown at the display. If "W&M different" is displayed Go to step 11 10. After downloading check if "COLDSTART" is required . Remove Jumper S13 (S15). When required switch PRG LOAD OFF. (left position) Reprogram iGEM if required ----- 11. Switch PRG LOAD ON. (right position) Go to step 1 and restart download. Make sure that you always fulfil local W&M demands.
--	--

When download is completed and COLDSTART jumper in place the display shows "COLD" on the sales display until the COLDSTART jumper (S15) is removed.

Also make sure to restore the communication jumpers to operate with POS protocol correct.

6.3.2 Bootstrapp Download, iGEM Master (supporter Kid) to iGEM Board in pump

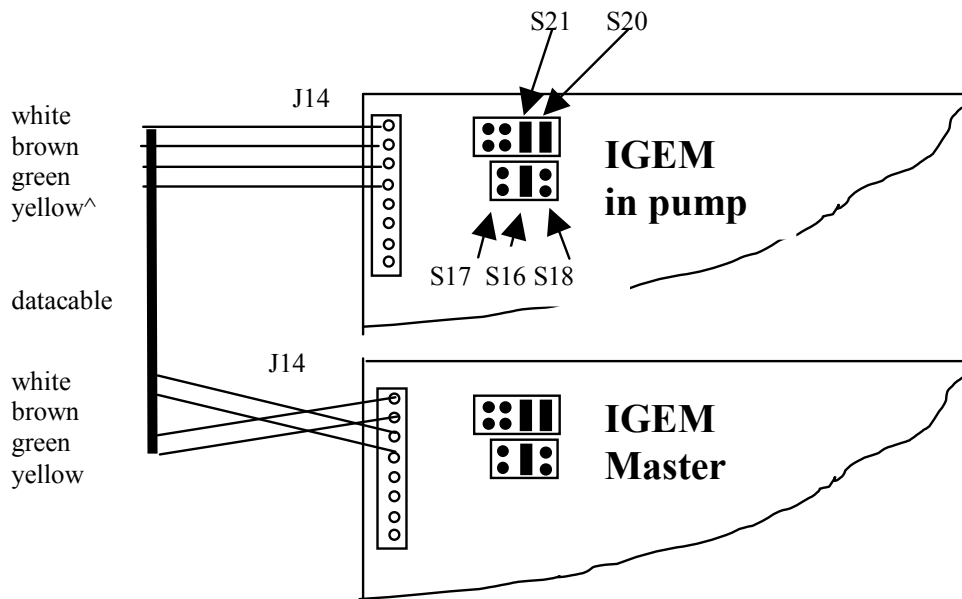

Note:

Set the iGEM Master (supporter kit) in function F21.09 to 4 (no maintenance mode entry without pressing the CRC button first).



- | | |
|---|---|
| <ol style="list-style-type: none"> 1. Turn off the power to the iGEM in pump. 2. Connect iGEM Master (supporter kit) and iGEM in pump (J14) via data cable 3. Connect power cable (24V) between IGEM Master, iGEM in PUMP and power supply in pump. 4. Check Jumper on the iGEM pump computer and supporter kit (picture above).
Set Jumper S20 and Jumper S16.
(S21 has no effect).
Set jumper S13 (BOOT) on the iGEM in pump and if required set S15 COLDSTART.
<u>Important:</u> do not set Jumper S17! 5. Switch on power. | <ol style="list-style-type: none"> 6. Press the CRC button on the iGEM Master. 7. On the iGEM Master display appears "bootld".
IF "E diff" appears go to step 10. 8. The file is now downloaded to the iGEM board, while each downloaded block is shown on the master's money display "PRO XX".
The volume display shows "0 242". 9. After downloading check if "COLDSTART" is required .
Remove Jumper S13 (S15).
When required switch PRG LOAD off.
(left position)
Reprogram iGEM if required ----- 10. Switch PRG LOAD ON (right position) and follow step 1 to restart the download.
Make sure that you always fulfil local W&M demands. |
|---|---|

When download is completed and COLDSTART jumper in place the display shows "COLD" on the sales display until the COLDSTART jumper (S15) is removed.
Also make sure to restore the communication jumpers to operate with POS protocol correct.

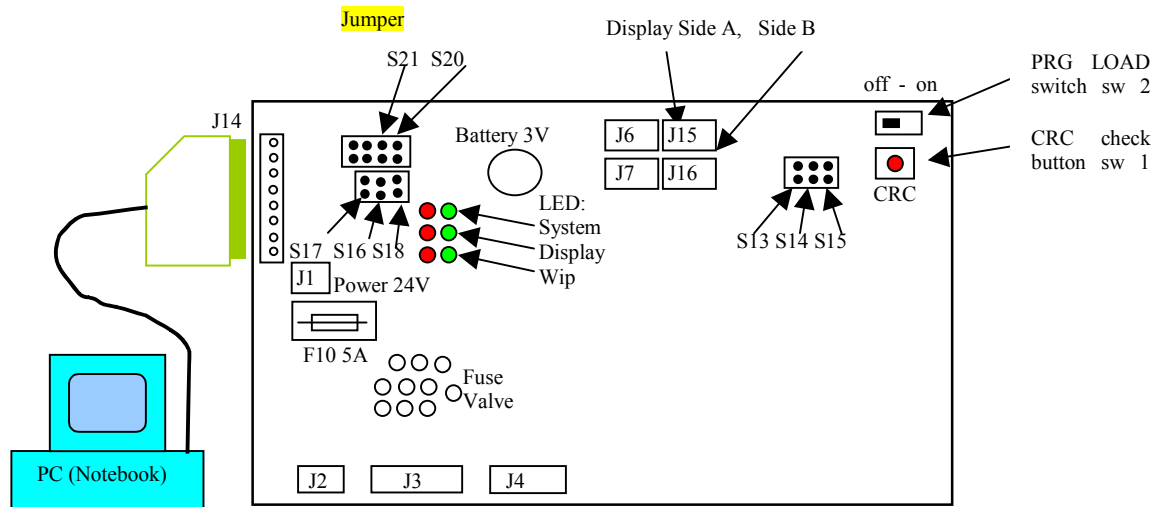
6.3.3 Function 98 Download PC (Notebook) to iGEM Board



Set jumper according link type

DART = S18, S20 and S21. 	LJCL = S16, S17, S20 and S21 
---	---



<ol style="list-style-type: none"> 1. Turn off the power to the iGEM in pump 2. Connect PC and iGEM via download cable, (PC com port to J14 on the iGEM board). 3. Switch on PC. 4. Check Jumper on the iGEM (picture). DART: S18, S20 and S21 LJCL: S16, S17, S20 and S21 if required S15 COLDSTART. 5. Switch on the iGEM. 6. Start ServTerm.exe software at PC and select protocol by TYPE button. 7. Press the CRC button on the iGEM pump computer to start download process. 8. On the pump display appears "PASS 1". 9. Enter service password 1 "xxxx" on PC and confirm by ENTER. On the pump display appears "PASS 2". 10. Enter service password 2 "xxxx" on PC and confirm by ENTER 	<ol style="list-style-type: none"> 11. Select Function Register 98, and confirm by ENTER twice. 12. On the pump display appears "PASS". 13. Enter Download Password "yy" from PC and press ENTER and select iGEM file. 12. The file is now downloaded to the iGEM board, while each downloaded block is shown at the PC "PRO XX". The pump display shows "burn". If "W&M different" is displayed Go to step 15 14. After downloading check if COLDSTART is required . Restore Jumpers. When required switch PRG LOAD OFF. (left position) Reprogram iGEM if required. <p>-----</p> <ol style="list-style-type: none"> 15. Switch PRG LOAD ON. (right position) Go to step 1 and restart download Make sure that you always fulfil local W&M demands.
--	--

When download is completed and COLDSTART jumper in place the display shows "COLD" on the sales display until the COLDSTART jumper (S15) is removed.
Also make sure to restore the communication jumpers to operate with POS protocol correct.

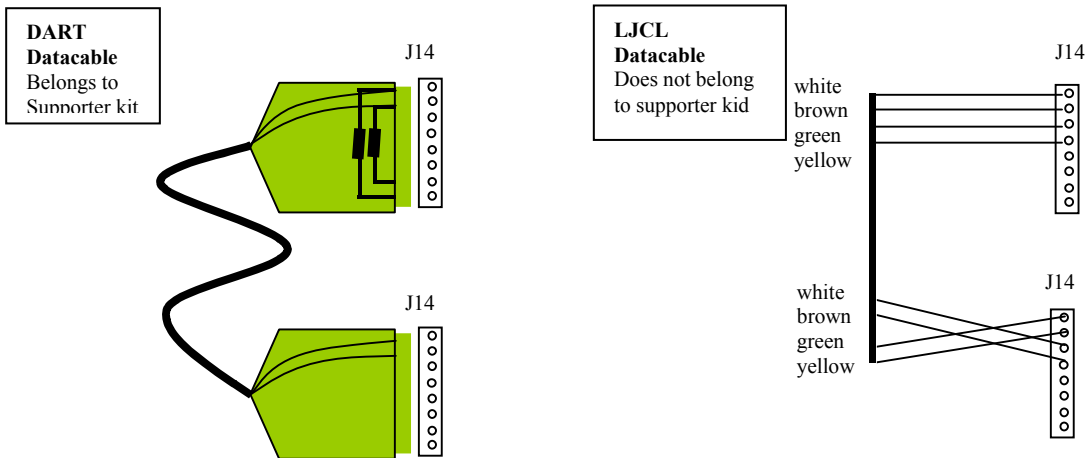
6.3.4 Function 98 iGEM Master to iGEM Board (pump)



Set jumper according link type

<p>DART = S18, S20 and S21.</p> 	<p>LJCL = S16, S17, S20 and S21</p> 
--	--

Note:

Set the iGEM Master (supporter kit) in function F21.09 to 4 (no maintenance mode entry without pressing the CRC button first).

<ol style="list-style-type: none"> 1. Turn off the power to the iGEM in pump. 2. Connect via data cable (J14) iGEM into pump and iGEM Master. 3. Connect power cable (24V) between iGEM Master and iGEM in pump and power supply. 4. Check Jumper on the iGEM (picture). DART: S18, S20 and S21 LJCL: S16, S20 and S21 if required S15 COLDSTART. <u>Important:</u> do not set Jumper S17! 5. Switch On power to iGEM Master and iGEM in pump 6. After 3 sec. Press the CRC button on the iGEM Master. After indication of program CRC press ENTER button. 7. On the pump display appears "PASS 1". 8. Enter password 1 "xxxx", and press ENTER. 9. On the pump display appears "PASS 2".. Enter password 2 "xxxx", and press ENTER. 10. Select Function register 98 and press ENTER. 11. On the pump display appears "Press". 	<ol style="list-style-type: none"> 12. Press the CRC button on the supporter kit. 13. The display on the supporter kit shows "dLoAd". Press ENTER on the iGEM pump computer. The display on the iGEM pump computer shows "PASS". 14. Enter Pass "yy" on the iGEM pump computer and press ENTER. 15. The file is now downloaded to the iGEM board, while each downloaded block is shown at the display "PRO XX". The pump display shows "burn". If "W&M different" is displayed Go to step 17 16. After downloading check if COLDSTART is required. Remove Jumpers. When required switch PRG LOAD off. (left position) Reprogram iGEM if required. ----- 17. Switch PRG LOAD ON. (right position) Go to step 1 and restart download Make sure that you always fulfil local W&M demands.
--	--





When download is completed and COLDSTART jumper in place the display shows "COLD" on the sales display until the COLDSTART jumper (S15) is removed.

Also make sure to restore the communication straps to operate with POS protocol correct.

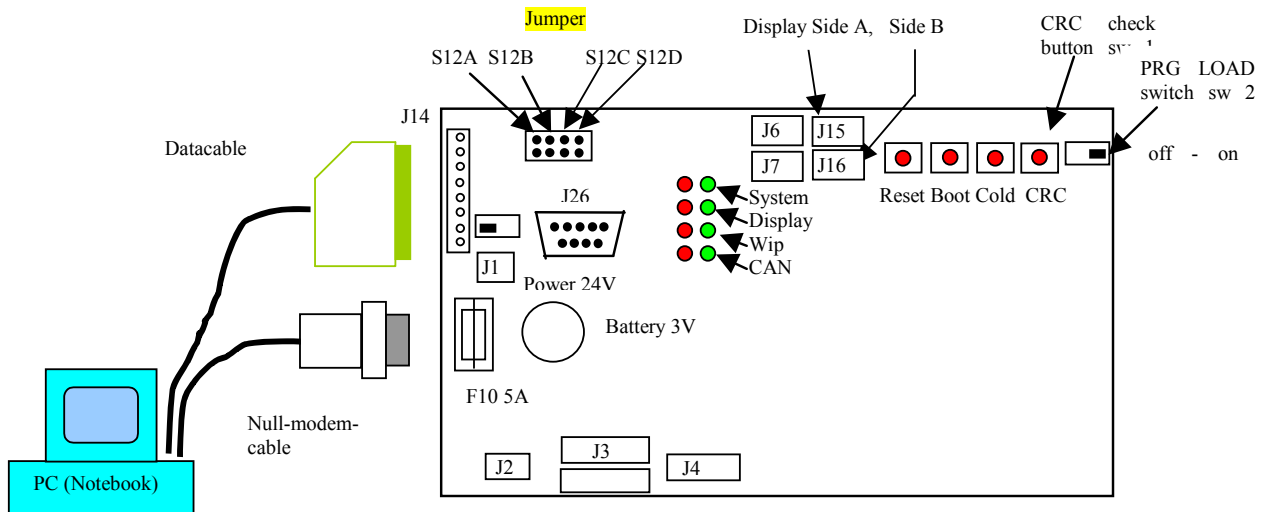
6.4 Download on 2:nd Generation iGEM Board

6.4.1 Bootstrapp Download PC (Notebook) to iGEM Board (pump) with J14



- | | |
|---|--|
| <ol style="list-style-type: none"> 1. Turn off the power to the iGEM in pump. 2. Connect PC and iGEM via download cable, (J14 or J26 on the iGEM Board). 3. Switch on PC 4. Check Jumper and Communication- Switch J1 (picture) on iGEM
 LJCL Datacable  J1= 
 Null-Modemcable  J1=  5. Switch on the iGEM 6. Press Reset and Boot. Hold Boot button 7. Longer than Reset button. 8. Start ServTerm.exe software at PC. Select "Boot" by BOOT button. "Entering GEM Boot Strap" appears. 9. Confirm "Entering GEM Boot Strap". 10. Select new iGEM.BIN file. | <ol style="list-style-type: none"> 11. The file is now downloaded to the iGEM board, while each downloaded block is shown at the display. If "W&M different" is displayed Go to step 12 12. If a COLDSTART is required press Reset and Cold button. Unhand Reset but hold Cold until the display shows "cold". When required switch PRG LOAD OFF. (left position) Reprogram iGEM if required <hr/> <ol style="list-style-type: none"> 13. Switch PRG LOAD ON. (right position) Go to step 1 and restart download. Make sure that you always fulfil local W&M demands. |
|---|--|



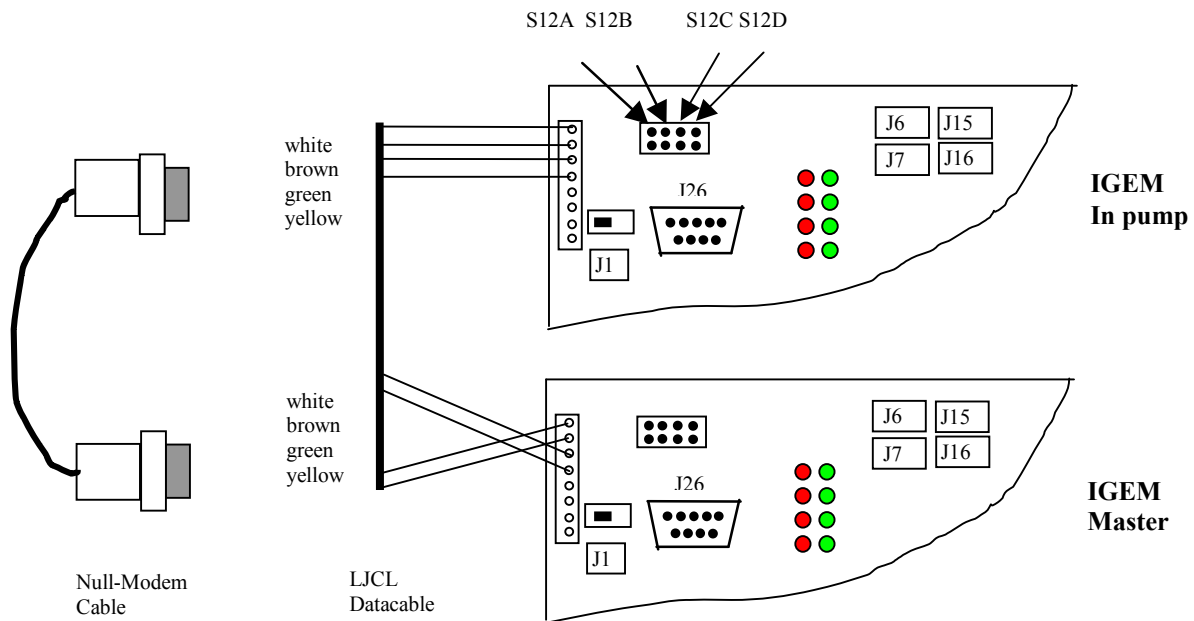

Also make sure to restore the communication jumpers and communication switch to operate with POS protocol correct.

6.4.2 Bootstrapp Download,iGEM Master (supporter Kid) to iGEM Board in pump



Note:









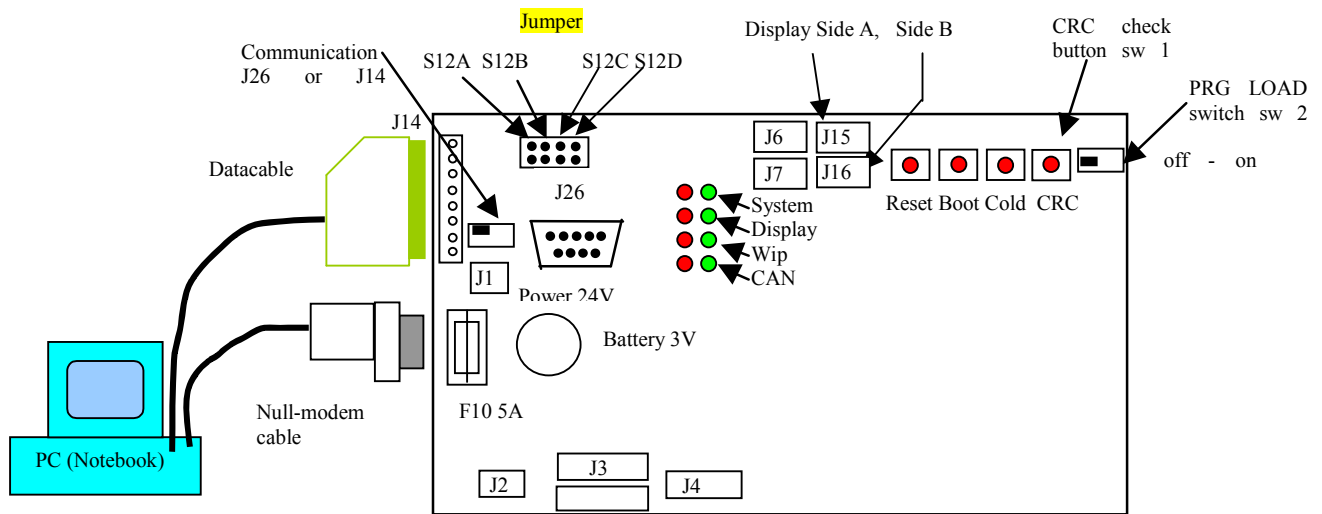









Set the iGEM Master (supporter kit) in function F21.09 to 4 (no maintenance mode entry without pressing the CRC button first).

- | | |
|--|--|
| <ol style="list-style-type: none"> 1. Turn off the power to the iGEM in pump. 2. Connect iGEM Master (supporter kit) and iGEM in pump (J14) via data cable 3. Connect power cable (24V) between IGEM Master, iGEM in PUMP and power supply in pump. 4. Check Jumper and communication switch J1 on the iGEM pump computer and supporter kit (picture above).
LJCL Datacable  J1= 
Null-Modemcable  J1=  5. Switch on power. Press Reset and Boot on the iGEM in pump. Hold Boot longer than Reset. 6. Press the CRC button on the iGEM Master 7. On the iGEM Master display appears "bootld".
IF "E diff" appears go to step 10 | <ol style="list-style-type: none"> 8. 9. The file is now downloaded to the iGEM board, while each downloaded block is shown on the master's money display "PRO XX". The volume display shows "0 242". 10. If COLDSTART is required press Reset and Cold button. Unhand Reset but hold Cold until the display shows "cold" When required switch PRG LOAD off. (left position)
Reprogram iGEM if required 11. Switch PRG LOAD ON (right position) and follow step 1 to restart the download. Make sure that you always fulfil local W&M demands. |
|--|--|

Also make sure to restore the communication jumpers and communication switch to operate with POS protocol correct.

6.4.3 Function 98 Download PC Notebook to iGEM Board with J14



- | | | | | | | | | | | | | | |
|---|---|---|---|---|----------------|---|-----|---|-------------------|---|-----|---|--|
| <ol style="list-style-type: none"> 1. Turn off the power to the iGEM in pump 2. Connect PC and iGEM via download cable, (PC com port to J14 or J26 on the board) 3. Switch on PC. 4. Check Jumper and Communication-Switch J1 on the iGEM
 <table border="0" style="margin-left: 20px;"> <tr> <td>DART Databable</td> <td></td> <td>J1=</td> <td></td> </tr> <tr> <td>LJCL Databable</td> <td></td> <td>J1=</td> <td></td> </tr> <tr> <td>Null- Modem Cable</td> <td></td> <td>J1=</td> <td></td> </tr> </table> 5. Switch on the iGEM. 6. Start ServTerm.exe software at PC and select protocol by TYPE button.(DART, 7. LJCL or TTL). 8. Press the CRC button on the iGEM pump computer to start download process. 9. On the pump display appears "PASS 1". 10. Enter service password 1 "xxxx" on PC and confirm by ENTER. On the pump display appears "PASS 2". 11. Enter service password 2 "xxxx" on PC and confirm by ENTER | DART Databable |  | J1= |  | LJCL Databable |  | J1= |  | Null- Modem Cable |  | J1= |  | <ol style="list-style-type: none"> 12. Select Function Register 98, and confirm by ENTER twice. 13. On the pump display appears "PASS". 14. Enter Download Password "yy" from PC and press ENTER and select iGEM file. 15. The file is now downloaded to the iGEM board, while each downloaded block is shown at the PC "PRO XX". The pump display shows "burn". If "W&M different" is displayed Go to step 16 16. If COLDSTART is required press Reset and Cold button. Unhand Reset but hold Cold until the display shows "cold". When required switch PRG LOAD OFF. (left position) Reprogram iGEM if required.
 <p>-----</p> 17. Switch PRG LOAD ON. (right position) Go to step 1 and restart download Make sure that you always fulfil local W&M demands. |
| DART Databable |  | J1= |  | | | | | | | | | | |
| LJCL Databable |  | J1= |  | | | | | | | | | | |
| Null- Modem Cable |  | J1= |  | | | | | | | | | | |





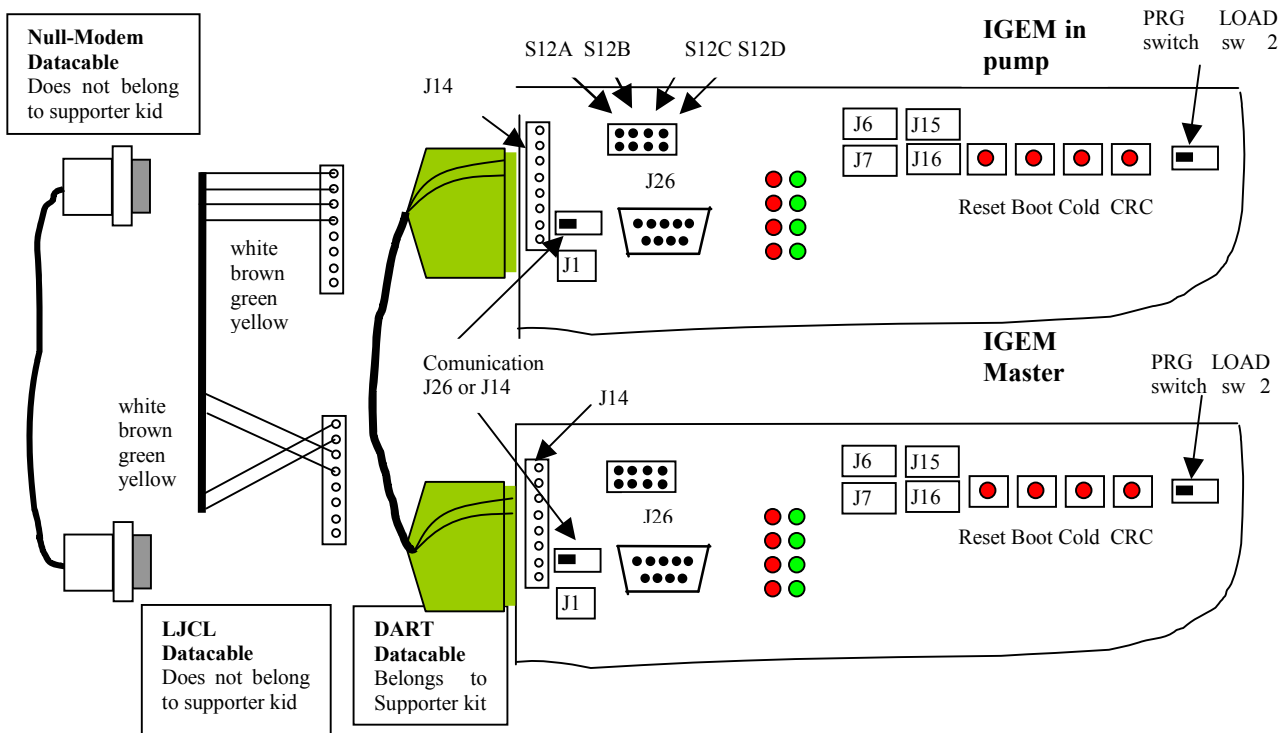













Also make sure to restore the communication jumpers and communication switch to operate with POS protocol correct.

6.4.4 Function 98 iGEM Master to iGEM Board (pump)



Note:

Set the iGEM Master (supporter kit) in function F21.09 to 4 (no maintenance mode entry without pressing the CRC button first).

- | | | | | | | | | | | | | | |
|---|---|---|---|---|----------------|---|-----|---|-----------------|---|-----|---|---|
| <ol style="list-style-type: none"> 1. Turn off the power to the iGEM in pump. 2. Connect via data cable (J14) or (J26) iGEM into pump and iGEM Master. 3. Connect power cable (24V) between iGEM Master and iGEM in pump and power supply 4. Check Jumper and communication switch J1 on the iGEM (picture).
 <table style="margin-left: 20px;"> <tr> <td>DART Datacable</td> <td></td> <td>J1=</td> <td></td> </tr> <tr> <td>LJCL Datacable</td> <td></td> <td>J1=</td> <td></td> </tr> <tr> <td>Null-Modemcable</td> <td></td> <td>J1=</td> <td></td> </tr> </table> 5. Switch On power to iGEM Master and iGEM in pump. 6. After 3 sec. Press the CRC button on the iGEM in pump. After indication of program CRC press ENTER button. 7. On the pump display appears "PASS 1". 8. Enter password 1 "xxxx", and press ENTER. 9. On the pump display appears "PASS 2".. Enter password 2 "xxxx", and press ENTER. 10. Select Function register 98 and press ENTER. 11. On the pump display appears "Press". | DART Datacable |  | J1= |  | LJCL Datacable |  | J1= |  | Null-Modemcable |  | J1= |  | <ol style="list-style-type: none"> 12. Press the CRC button on the supporter kit. 13. The display on the supporter kit shows "dLoAd". Press ENTER on the iGEM pump computer. The display on the iGEM pump computer shows "PASS". 14. Enter Pass "yy" on the iGEM pump computer and press ENTER. 15. The file is now downloaded to the iGEM board, while each downloaded block is shown at the display "PRO XX". The pump display shows "burn". If "W&M different" is displayed Go to step 17 16. If COLDSTART is required press Reset and Cold button. Unhand Reset but hold Cold until the display shows "cold". When required switch PRG LOAD off. (left position) Reprogram iGEM if required. <p>-----</p> <ol style="list-style-type: none"> 17. Switch PRG LOAD ON. (right position) Go to step 1 and restart download Make sure that you always fulfil local W&M demands. |
| DART Datacable |  | J1= |  | | | | | | | | | | |
| LJCL Datacable |  | J1= |  | | | | | | | | | | |
| Null-Modemcable |  | J1= |  | | | | | | | | | | |

Also make sure to restore the communication straps and communication switch to operate with POS protocol correct.



8 Market & Service

Sweden

Dresser Wayne AB

Limhamnsvägen 109
Box 30049
SE-200 61 Malmö

Tel + 46 40-36 05 00
Fax + 46 40-15 03 81

www.wayne.se
E-mail: info@wayne.se

Italy

**Dresser Wayne Pignone -
Deg Italia S.p.a.**

Via Giovanni Piantanida, 12
50127 FIRENZE (FI), Italy

Tel +39 055 3039 200
Fax +39 055 3039 007

UK

Dresser Wayne, DI UK Ltd

Butlerfield Industrial Estate,
Bonnyrigg, Midlothian,
Scotland. EH19 3JQ

Tel. +44 (0)1875 402141
Fax +44 (0)1875 400010

E-mail: Sales@bonx-wayne.com

Germany

Wayne Germany

Dresser Europe GmbH

Grimsehlstr. 44
37574 Einbeck

Tel. +49 (0) 5561 / 794 -0
Fax +49 (0) 5561 / 794 -187

E-Mail: info@wayne-europe.com





More than a century of experience Über 100 Jahre Erfahrung Mer än 100 års erfarenhet Более, чем столетний опыт работы



Wayne Dresser develops, manufactures and markets complete operative systems for fuel handling at service stations. Everything from development and design to efficient production and assembly of components is pursued under one roof.

Wayne Dresser entwickelt, produziert und vermarktet komplette funktionierende Systeme für die Abgabe von Kraftstoffen an Tankstellen.. Von der Entwicklung über das Design bis zur Herstellung und Installation liefern wir alles aus einer Hand.

Wayne Dresser utvecklar, tillverkar och marknadsför kompletta operativa system för drivmedelshandling på servicestationer. Under ett och samma tak ryms allt från utveckling och konstruktion till rationell tillverkning och sammansättning av komponenter.

Wayne Dresser разрабатывает, производит и продает совершенные оперативные системы для торговли топливом на станциях обслуживания. Все начиная от разработок и конструкции до эффективного производства и сборки компонентов происходит в пределах одного предприятия.

The operations of Wayne Dresser comprise four interacting parts:

- Equipment such as petrol pumps, payment terminals, point-of-sale terminals and service station operative systems.
- Software for recording and for internal communication at the station, as well as between the station and the oil company, banks and credit institutes.
- Project design with overall responsibility to the customer.
- Field service, technical support and supply of spare parts.

Wayne Dresser makes it easier for the motorist to fill up and make his motoring purchases, while effectively meeting the needs of the service station owner for operating supervision and for conforming to the demands of the authorities on measuring accuracy, minimising pollution and ensuring safety.

Die Niederlassungen von Wayne Dresser umfassen vier ineinander greifende Bereiche:

- Ausrüstungen wie Zapfsäulen, Zahlterminals, Kassenterminals und Tankstellensysteme
- Software für Registrierung und Kommunikation auf der Tankstelle u. zwischen Station und Mineralölfirma sowie Banken und Kreditinstituten.
- Projektgestaltung mit umfassender Verantwortlichkeit dem Kunden gegenüber.
- Service, technische Unterstützung und Lieferung von Ersatzteilen.

Wayne Dresser erleichtert dem Fahrer die Betankung und damit verbundene Einkäufe, unterstützt gleichzeitig den Stationär bei der übersichtlichen Führung seines Betriebes unter Berücksichtigung der behördlichen Vorschriften hinsichtlich Messgenauigkeit, Umwelt- und Sicherheitsauflagen.

Verksamheten omfattar fyra samverkande delar:

- Utrustning som bensinpumpar, betalterminaler, butiksterminaler och stationsdatorer.
- Programvara för registrering och kommunikation internt på stationen samt mellan stationen och oljebolaget, banker och kreditinstitut.
- Projektering med totalansvar gentemot uppdragsgivaren.
- Service på fältet, teknisk support och reservdelsförsörjning.

Wayne Dresser gör det lättare för bilisten att tanka och handla. Samtidigt tillgodoses stationsägarens krav på en effektiv driftskontroll och myndighetskraven på mätnoggrannhet, miljövänlighet och driftssäkerhet.

Действия Wayne Dresser включают четыре взаимосвязанных направления:

- Оборудование, например, топливораздаточные колонки, платежные терминалы, терминалы точек продажи и системы управления АЗС.
- Программное обеспечение для регистрации и для внутренней связи на АЗС, а также между АЗС и нефтяной компанией, банками и институциями кредитов.
- Проектирование с полной ответственностью к клиенту.
- Обслуживание на местах, техническая поддержка и поставка запасных частей.

Wayne Dresser упрощает процесс заправки и приобретения покупок при эффективном согласовании потребностей владельца АЗС для оперативного управления и для соблюдения требований государственных и метрологических служб, а также уменьшения загрязнения окружающей среды и обеспечения безопасности.